

This page is part of your document - DO NOT DISCARD



20100858621



Pages:
0031

Recorded/Filed in Official Records
Recorder's Office, Los Angeles County,
California

06/23/10 AT 08:00AM

FEES:	0.00
TAXES:	0.00
OTHER:	0.00
PAID:	0.00

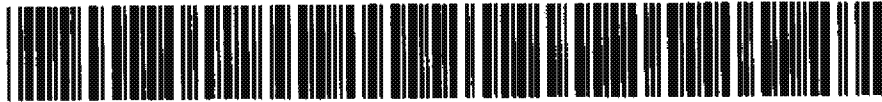

LEADSHEET

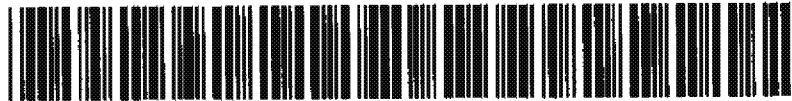

201006230180006

00002553243

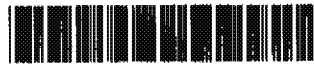

002745067

SEQ:
22

DAR - Title Company (Hard Copy)

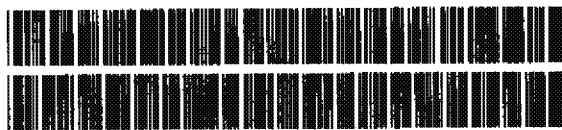

THIS FORM IS NOT TO BE DUPLICATED

T55

Fidelity National Title Company

RECORDING REQUESTED BY AND
WHEN RECORDED RETURN
TO:



CITY OF INGLEWOOD

One Manchester Boulevard

Inglewood, CA 90301

Attn: City Administrator
Timothy E. Wanamaker

No Documentary Transfer Tax due – Grantee is a public agency
(Rev. & Tax, Code Section 11922)

725125255-SB

Ptms of (Space above line for recorder's use only)
4025-011-028 and 029

GRANT DEED AND IRREVOCABLE OFFER OF DEDICATION

FOR VALUABLE CONSIDERATION, receipt of which is hereby acknowledged, HOLLYWOOD PARK LAND COMPANY, LLC, a Delaware limited liability company ("Grantor"), does hereby GRANT to the CITY OF INGLEWOOD, a municipal corporation ("Grantee"), all of that certain real property in the City of Inglewood, County of Los Angeles, State of California, as more particularly described in Exhibit "A" attached hereto and made a part hereof by this reference (the "Land").

FURTHER, Grantor hereby makes this IRREVOCABLE OFFER OF DEDICATION of that certain real property in the City of Inglewood, County of Los Angeles, State of California, as more particularly described on Exhibit "B" attached hereto and made a part hereof by this reference (the "Prairie Avenue ROW"), an easement for public right-of-way and street purposes.

Such GRANT AND IRREVOCABLE OFFER OF DEDICATION is expressly subject to the encumbrances and other matters of record shown on the attached Exhibit "C", non-delinquent real property taxes, and all matters that would be disclosed by a survey or physical inspection. In addition, the Grantee expressly agrees that any use of the Land must be a permissible use for the Civic Site pursuant to the Hollywood Park Specific Plan (adopted as City of Inglewood Ordinance No. 09-012) (the "Specific Plan") and Section 16.9 of the Development Agreement by and between the City of Inglewood and Hollywood Park Land Company, LLC (adopted by City of Inglewood Ordinance No. 09-14) (the "Development Agreement"); *provided, however*, that notwithstanding anything to the contrary contained in this GRANT DEED AND IRREVOCABLE OFFER OF DEDICATION, the Specific Plan or the Development Agreement, the Grantee acknowledges that the following uses for the Land are not permitted: market-rate housing, retail, commercial or office unless the commercial or office use is accessory to an otherwise permissible civic use as specified in the Specific Plan. The Grantee may also select as a proposed use on the Land, affordable housing or affordable senior housing use of up to 200 residential units, provided that the standards and design are consistent with the Specific Plan.

Execution Version

NOTWITHSTANDING anything to the contrary contained herein, Grantor hereby reserves the right for itself, its heirs, successors and/or assigns the following easements in gross and easements appurtenant for the benefit of the property described in Exhibit "D":

1. An easement for the construction, reconstruction, maintenance, alteration, replacement, repair construction, of the necessary cut and fill slope(s) and appurtenances incidental thereto, with the right of ingress and egress to and from the same of Grantor's vehicles and equipment or the vehicles and equipment of Grantor's authorized employees, licensees, contractors, developers, agents (each a "Permitted Party," collectively, the "Permitted Parties"), in, upon, over, under and across strips of land ten feet (10') wide around the north, east and west perimeter of the Land as shown on Exhibit "E" attached hereto, and incorporated herein by this reference (the "Construction and Slope Easement"). This Construction and Slope Easement shall include the right to grade, fill, topsoil seed and to maintain the same for purposes of stabilizing the soil, preventing erosion, or improving the aesthetic aspects of the Land, including but not limited to the planting of landscape and plant material. Grantor and its Permitted Parties shall comply with applicable National Pollution Discharge Elimination System (NPDES) permit requirements when exercising its rights under the Construction and Slope Easement. The Construction and Slope Easement shall remain in full force and effect until such time as the Grantor gives written notice to the Grantee that the Construction and Slope Easement is no longer needed. At such time, the Construction and Slope Easement shall terminate and be of no further force and effect.

2. A non-exclusive easement in, upon, over, under and across the area described as the "Well Site Area" on Exhibit "F" attached hereto, and incorporated herein by this reference, for the purpose of continued maintenance of and access to the Regional Water Quality Control Board Groundwater Monitoring Well on the Land (the "Monitoring Well") to take samples and otherwise use the Monitoring Well for its intended purposes, with the right of ingress and egress to and from the same of Grantor's vehicles and equipment or a Permitted Party's vehicles and equipment during normal business hours (the "Monitoring Well Easement"). Grantor shall operate the Monitoring Well under the jurisdiction of the Regional Water Quality Control Board, and in accordance with the Soil Management Plan approved by the Regional Water Quality Control Board. Upon a determination by the Regional Water Quality Control Board that the required sampling and monitoring of the Monitoring Well is complete and any other related actions that may be required by the Regional Water Quality Control Board of Grantor (including but not limited to the capping of removal of the well), Grantor shall so notify the Grantee, and the Monitoring Well Easement shall automatically terminate and be of no further force and effect.

3. To the extent Grantee (i) has not commenced construction of improvements relative to its chosen use for the Land, or (ii) has commenced construction but is not diligently pursuing completion of said improvements, a non-exclusive easement in, upon, over, under and across the Land and Prairie Avenue ROW, to accommodate any necessary rough grading and construction of required street and other public improvements by Grantor or a Permitted Party with the right of ingress and egress to and from the same for Grantor's vehicles and equipment or the vehicles

and equipment of a Permitted Party, to allow Grantor or a Permitted Party to accomplish rough grading and construction of required street and other public improvements in accordance with any approved grading plan, and to implement the required grading and storm drainage and street and other public improvement measures required in accordance with Vesting Tentative Tract Map No. 69906 (approved by City of Inglewood Resolution No. 09-73) (the "Rough Grading and Street Improvement Easement"). Grantor and its Permitted Parties shall comply with the approved Storm Water Pollution Prevention Plan (SWPPP) when exercising its rights under the Rough Grading and Street Improvement Easement.

Upon completion of the rough grading and construction of required drainage, street and other public improvements on the Land and the Prairie Avenue ROW as applicable, Grantor and the Permitted Parties shall remove all vehicles, heavy equipment, machinery, construction supplies and debris from the Land or Prairie Avenue ROW, respectively, at which time the Rough Grading and Street Improvement Easement shall automatically terminate and be of no further force and effect.

To the extent (a) Grantor has not commenced rough grading and construction of required drainage, street and other public improvements on the Land and the Prairie Avenue ROW, as applicable, prior to the time Grantee has secured a building permit and commenced construction of improvements relative to its chosen use for the Land, and (b) so long as Grantee has commenced and is diligently pursuing completion of said improvements with respect to its chosen use of the Land, the Grantor shall have no right to utilize the Rough Grading and Street Improvement Easement, and upon completion of Grantee's improvements relative to its chosen use for the Land, the Rough Grading and Street Improvement Easement shall automatically terminate and be of no further force and effect. To the extent Grantor has not commenced rough grading and construction of required drainage, street and other public improvements on the Land and the Prairie Avenue ROW, as applicable, prior to the time Grantee has secured a building permit and commenced construction of improvements relative to its chosen use for the Land, to assist the Grantee in construction of its improvements relative to the chosen use for the Land, Grantor hereby grants to Grantee a non-exclusive easement in, upon, over, under and across a strip of land ten feet (10') wide on that portion of the property described in Exhibit D that abuts the southern perimeter of the Land as shown on Exhibit E (the "Grantee Construction and Slope Easement"). The Grantee Construction and Slope Easement shall include the right to grade, fill, topsoil seed and to maintain the same for purposes of stabilizing the soil or preventing erosion. Grantee shall comply with applicable NPDES permit requirements when exercising its rights under the Grantee Construction and Slope Easement. The Grantee Construction and Slope Easement shall remain in full force and effect until such time as Grantee completes construction of the improvements with respect to its chosen use for the Land, at which time the Grantee Construction and Slope Easement shall terminate and be of no further force and effect. In addition, construction activities shall conform to the required grading and storm drainage and street and other public improvement measures required in accordance with Vesting Tentative Tract Map No. 69906 (approved by City of Inglewood Resolution No. 09-73).

4. A temporary, non-exclusive easement in, upon, over, under and across the "Designated Area" (as defined below) together with the right of ingress and egress to and from the same for Grantor's vehicles and equipment or the vehicles and equipment of any Permitted

5

Party, and for the installation, planting, operation, maintenance, repair and replacement of landscaping and landscape improvements, irrigation and irrigation systems, slopes, soil, and other improvements or incidental utilities now or hereafter located on the Designated Areas (including, without limitation, the right to exercise any of the foregoing easement rights in order to ensure compliance with any permits, laws, regulations, and runoff and erosion control measures applicable to the Land and surrounding areas and/or in order to perform any mitigation measures) (the "Landscape Easement"). Grantor shall have the right, but not the obligation to exercise its rights under the Landscape Easement. Whether undertaken by Grantor or Grantee, all designs, materials, planting palettes, landscaping improvements and maintenance standards within the Designated Area shall comply with the Specific Plan. Grantor's rights with respect to the Landscape Easement may be assigned at any time to any homeowners' association or property owners' association having authority over the Land or any real property adjacent or proximate to the Land.

The Landscape Easement shall remain in full force and effect until such time as the Grantee has completed construction of improvements relative to Grantee's chosen use for the Land; *provided, however*, Grantee may give earlier written notice to Grantor that Grantee shall thenceforth assume maintenance responsibility for the Designated Area. At such time, the temporary rights granted under the Landscape Easement shall automatically terminate and be of no further force and effect.

To the extent Grantor has exercised its rights under the Landscape Easement, and Grantee commences construction of improvements relative to Grantee's chosen use for the Land, Grantor's maintenance obligation shall be limited to ordinary maintenance of the Designated Area, and Grantor shall have no obligation to repair or replace landscaping and landscaping improvements that may be damaged by Grantee's construction activities on the Land or other extraordinary causes.

For purposes of this Landscape Easement, except for any areas where structural improvements have been made, the term "Designated Areas" shall mean the thirty foot (30') setback area along the section of Prairie Avenue abutting the Land, and the twenty-five foot (25') setback area along the section of Arbor Vitae Street abutting the Land as shown on Exhibit 2-26 of the Specific Plan.

5. A non-exclusive easement in, upon, over, under and across the portion of the Land as shown on Exhibit "G" attached hereto, and incorporated herein by this reference, for operation and maintenance of an existing pipeline utilized for domestic water purposes and related activities (the "Potable Waterline") together with all appurtenances (the "Potable Waterline Easement" identified on Exhibit "G" as the "20' Domestic Water Maintenance Easement"); a non-exclusive easement in, upon, over, under and across the portion of the Land as shown on Exhibit "H" attached hereto, and incorporated herein by this reference, for an existing pipeline utilized for reclaimed water purposes and related activities (the "Reclaimed Waterline" identified on Exhibit "H" as the "20' Reclaimed Water Maintenance Easement") together with all appurtenances (the "Reclaimed Waterline Easement"); and a non-exclusive easement in, upon, over, under and across the portion of the Land referred to in Item 4 of Exhibit "C" (the "BP Pipeline Easement"), on which is currently located a natural gas pipeline (the "BP Pipeline").

6

Grantor and its Permitted Parties shall have the right at any time upon reasonable notice to enter upon the Land and take actions associated with removal of the Potable Waterline, the Reclaimed Waterline, and the BP Pipeline. To the extent the Potable Waterline Easement, the Reclaimed Waterline Easement or the BP Pipeline Easement, interfere with the Grantee's chosen use for the Land, upon the Grantee's written request to the Grantor, the Grantor or its Permitted Parties, shall enter upon the Land and remove the Potable Waterline, the Reclaimed Waterline, or the BP Pipeline, as applicable, within the later to occur of August 7, 2012, or the date that the Grantee has secured the building permits for use of the Land and is ready to commence construction. If Grantor or its Permitted Parties have not otherwise removed the Potable Waterline, Reclaimed Waterline or BP Pipeline within the aforementioned time frame following the giving of notice by Grantee, then Grantor shall reimburse the Grantee for the costs to remove and relocate the subject water and gas lines. Upon completion of the removal of the Potable Waterline, the Potable Waterline Easement shall automatically terminate and be of no further force and effect. Upon completion of the removal of the BP Pipeline, the Grantor shall use commercially reasonable efforts to secure the quitclaim of the BP Pipeline easement from the holder thereof and deliver it to the Grantee. Upon completion of the removal of the Reclaimed Waterline, the Reclaimed Waterline Easement shall automatically terminate and be of no further force and effect.

6. An easement in, upon, over, under and across that minimum portion of the Land required by approved improvement plans for the construction, reconstruction, installation, inspection, maintenance, operation, alteration, replacement repair of traffic control signals, devices and facilities for the control, direction and regulation of pedestrian and vehicular traffic; together with the necessary outlets, conduits, wires, cables, standards, connections, channels, tunnels, excavation and other appurtenances in, upon, over, under and across the Land in the location required by approved improvement plans (the "Traffic Signal Equipment Easement"). Upon approval of the final improvement plans for the traffic control signals, devices and facilities, Grantor shall record a notice identifying the precise final dimensions of the Traffic Signal Equipment Easement area. The Traffic Signal Equipment Easement shall include the right of ingress and egress to and from the same of Grantor's vehicles and equipment or a Permitted Party's vehicles and equipment. Upon Grantee's acceptance of the traffic signal improvements described herein, the Traffic Signal Equipment Easement shall automatically terminate and be of no further force and effect.

7. A non-exclusive easement in, upon, over, under and across the portion of the Land as shown on Exhibit "I" attached hereto, and incorporated herein by this reference, for maintenance and repair of an existing monument sign (the "Monument Sign") utilized for identifying the current racetrack activities of the Grantor on the property described in Exhibit D, (the "Monument Sign Easement"). The Monument Sign shall be removed as part of the work related to utilization of the Rough Grading and Street Improvement Easement, provided that, to the extent the Monument Sign interferes with the Grantee's chosen use for the Land and Grantor or a Permitted Party have not yet begun rough grading and construction of required street and other public improvements on the Land, then, upon the Grantee's written request to the Grantor, the Grantor or its Permitted Parties, shall enter upon the Land and remove the Monument Sign no later than the date that the Grantee has secured the building permits for construction of improvements relative to Grantee's chosen use of the Land and is ready to commence construction. If Grantor or its Permitted Parties have not otherwise removed the Monument Sign within the

aforementioned time frame following the giving of notice by Grantee, then Grantor shall reimburse the Grantee for the costs to remove the Monument Sign. Upon completion of the removal of the Monument Sign, the Monument Sign Easement shall automatically terminate and be of no further force and effect.

Except as otherwise expressly provided herein, in the case of each of the nine (9) easements reserved herein to Grantor, Grantor shall have the further right to use during construction such areas adjacent to the easement herein granted as may be reasonably necessary for the performance of the work and for access to the work during construction. Grantee shall not erect any building, fence or other structure on said easement, which will in any way interfere with Grantor's rights and operations hereunder. Grantee shall not increase or decrease or permit to be increased or decreased, the now existing ground elevations of said easement without the prior written consent of Grantor. In the event Grantor transfers all or a portion of its interest in the real property described in Exhibit "D," Grantor may also transfer its rights otherwise reserved to Grantor by the easements under this GRANT AND IRREVOCABLE OFFER OF DEDICATION to a designee.

Grantor shall and does hereby agree to indemnify and hold harmless Grantee from any and all damages, loss or liability by reason of injury to property or third person occasioned by its use of the Monitoring Well Easement, the Construction and Slope Easement, the Rough Grading and Street Improvement Easement, the Landscape Easement, the Reclaimed Waterline Easement, the Potable Waterline Easement, the BP Pipeline Easement, the Traffic Signal Equipment Easement and the Monument Sign Easement or act of omission, neglect or wrong doing of Grantor or Permitted Parties with regard to the Monitoring Well Easement, the Construction and Slope Easement, the Rough Grading and Street Improvement Easement, the Landscape Easement, the Reclaimed Waterline Easement, the Potable Waterline Easement, the BP Pipeline Easement, the Traffic Signal Equipment Easement and the Monument Sign Easement. Grantor shall, at its own cost and expense, defend and protect Grantee against such claims and demands.

Any notice to Grantee or Grantor required by this GRANT AND IRREVOCABLE OFFER OF DEDICATION shall be in writing and given by delivering the same to such party in person or by sending the same by registered or certified mail, or express mail, return receipt requested, with postage prepaid, to the party's mailing address. The respective mailing addresses of Grantee and Grantor are, until changed as hereinafter provided, the following:

Grantee:	City of Inglewood One Manchester Boulevard Inglewood, California 90301 Attention: City Administrator
with a copy to:	Office of the City Attorney One Manchester Boulevard Inglewood, California 90301

8

Grantor: Hollywood Park Land Company, LLC
c/o Stockbridge Real Estate Funds
Four Embarcadero Center, Suite 3300
San Francisco, CA 94111
Attention: Christopher Meany

with a copy to: Hollywood Park Land Company, LLC
c/o Wilson Meany Sullivan, LLP
100 Wilshire Boulevard, Ste 940
Santa Monica, California 90401
Attention: Douglas Moreland

with a copy to: Gibson, Dunn & Crutcher LLP
333 S. Grand Avenue
Suite 4900
Los Angeles, California 90071
Attention: Amy R. Forbes

Grantor or Grantee may change its mailing address at any time by giving written notice of such change to the other party in the manner provided herein at least ten (10) days prior to the date such change is effected. All notices under this GRANT DEED AND IRREVOCABLE OFFER OF DEDICATION shall be deemed given, received, made or communicated on the date personal delivery is effected or, if mailed, on the delivery date or attempted delivery date shown on the return receipt.

This GRANT DEED AND IRREVOCABLE OFFER OF DEDICATION shall be binding upon and inure to the benefit of the respective successors and assigns of Grantor and Grantee.

[SIGNATURE PAGES FOLLOW]

IN WITNESS WHEREOF, Grantor and Grantee have caused this instrument to be executed on this 20th day of January, 2010.

“GRANTOR”

HOLLYWOOD PARK LAND COMPANY, LLC, a Delaware limited liability company

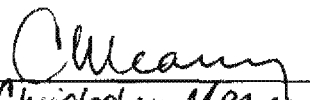
By: 
Name: Christopher Meany
Title: Senior Vice President

"GRANTEE"

CITY OF INGLEWOOD,
a municipal corporation

By: *Ralph L. Franklin*

Name: RALPH L. FRANKLIN

Its: Mayor Pro Tem

ATTEST:

James H. Lee
City Clerk:

APPROVED AS TO FORM:

Carl P. Sandoz
City Attorney:

State of California)

County of Los Angeles)

On January 20, 2010 before me, Gloria M. Chacon, a Notary Public, personally appeared Christopher Meany, who proved to me on the basis of satisfactory evidence to be the person~~s~~ whose name~~s~~ is/~~are~~ subscribed to the within instrument and acknowledged to me that he/~~she~~/they executed the same in his/~~her~~/their authorized capacity~~s~~, and that by his/~~her~~/their signature~~s~~ on the instrument the person~~s~~, or the entity upon behalf of which the person~~s~~ acted, executed the instrument.

I certify under PENALTY OF PERJURY under the laws of the State of California that the foregoing paragraph is true and correct.

WITNESS my hand and official seal.

Signature *Gloria M. Chacon*

(Seal)

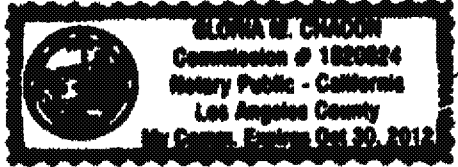

12

**NOTARY SEAL
GOVERNMENT CODE SECTION 27361.7**

I CERTIFY UNDER PENALTY OF PERJURY THAT THE NOTARY SEAL ON THE DOCUMENT TO WHICH THIS STATEMENT IS ATTACHED READS AS FOLLOWS:

NAME OF NOTARY Gloria M. Chacon

DATE COMMISSION EXPIRES October 30, 2012

COMMISSION NUMBER 1820824

PLACE OF EXECUTION Los Angeles

DATE June 22, 2010

SIGNED 

ACKNOWLEDGMENT

State of California)
County of Los Angeles

On 3/16/10 before me, Tunisia Johnson, a Notary Public,
personally appeared Ralph Franklin
who proved to me on the basis of satisfactory evidence to be the person(s) whose name(s) is/are
subscribed to the within instrument and acknowledged to me that he/she/they executed the same
in his/her/their authorized capacity(ies), and that by his/her/their signature(s) on the instrument
the person(s), or the entity upon behalf of which the person(s) acted, executed the instrument.

I certify under PENALTY OF PERJURY under the laws of the State of California that the
foregoing paragraph is true and correct.

WITNESS my hand and official seal.

Signature Tunisia Johnson

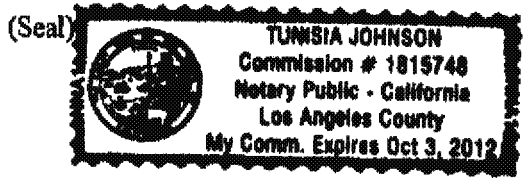

EXHIBIT "A"
LEGAL DESCRIPTION
LOT "A"

THE LAND REFERRED TO HEREIN BELOW IS SITUATED IN THE CITY OF INGLEWOOD, COUNTY OF LOS ANGELES, STATE OF CALIFORNIA, AND IS DESCRIBED AS FOLLOWS:

A PORTION OF PARCEL "C" OF PARCEL MAP NO. 25640, IN THE CITY OF INGLEWOOD, COUNTY OF LOS ANGELES, STATE OF CALIFORNIA, AS PER MAP FILED IN BOOK 289 PAGES 53 TO 61 INCLUSIVE OF PARCEL MAPS, IN THE OFFICE OF THE COUNTY RECORDER OF SAID COUNTY, AND AS AMENDED BY A CERTIFICATE OF CORRECTION RECORDED ON JUNE 28, 2000 AS INSTRUMENT NO. 00-0993688 OF OFFICIAL RECORDS, DESCRIBED AS FOLLOWS:

BEGINNING AT THE CENTERLINE INTERSECTION OF ARBOR VITAE AND PRAIRIE AVENUE, AS SHOWN ON SAID PARCEL MAP, THENCE THE FOLLOWING NUMBERED COURSES:

1. SOUTH 00° 08' 11" WEST, 59.96 FEET ALONG THE CENTERLINE OF PRAIRIE AVENUE,
2. SOUTH 89° 51' 49" EAST, 63.00 FEET, PERPENDICULAR TO SAID CENTERLINE, TO THE **TRUE POINT OF BEGINNING**, SAID POINT ALSO BEING THE BEGINNING OF A NON-TANGENT CURVE, CONCAVE SOUTHEASTERLY, HAVING A RADIUS OF 17.00 FEET,
3. NORTHEASTERLY ALONG SAID CURVE, THROUGH A CENTRAL ANGLE OF 89° 59' 54", AN ARC DISTANCE OF 26.70 FEET, TO THE BEGINNING OF A TANGENT LINE,
4. SOUTH 89° 51' 55" EAST, 431.90 FEET, ALONG SAID TANGENT LINE, TO THE BEGINNING OF A TANGENT CURVE, CONCAVE SOUTHWESTERLY, HAVING A RADIUS OF 15.00 FEET,
5. SOUTHEASTERLY ALONG SAID CURVE, THROUGH A CENTRAL ANGLE OF 90° 00' 00", AN ARC DISTANCE OF 23.56 FEET, TO THE BEGINNING OF A TANGENT LINE,
6. SOUTH 00° 08' 05" WEST, 357.84 FEET, ALONG SAID TANGENT LINE,
7. NORTH 89° 51' 55" WEST, 475.91 FEET, TO THE BEGINNING OF A LINE THAT IS PARALLEL WITH, AND 51.00 FEET EASTERLY OF THE CENTERLINE OF SAID PRAIRIE AVENUE,
8. NORTH 00° 08' 11" EAST, 84.84 FEET, ALONG SAID PARALLEL LINE, TO THE BEGINNING OF A TANGENT CURVE, CONCAVE SOUTHEASTERLY, HAVING A RADIUS OF 66.50 FEET,
9. NORTHERLY ALONG SAID CURVE, THROUGH A CENTRAL ANGLE OF 22° 24' 10", AN ARC DISTANCE OF 26.00 FEET, TO THE BEGINNING OF A REVERSE CURVE, CONCAVE NORTHWESTERLY, HAVING A RADIUS OF 92.50 FEET, A RADIAL LINE TO SAID CURVE BEARS SOUTH 67° 27' 39" EAST,
10. NORTHERLY ALONG SAID CURVE, THROUGH A CENTRAL ANGLE OF 22° 24' 10", AN ARC DISTANCE OF 36.17 FEET, TO THE BEGINNING OF A TANGENT LINE, SAID TANGENT LINE BEING PARALLEL WITH, AND 63.00 FEET EASTERLY OF, THE CENTERLINE OF SAID PRAIRIE AVENUE,
11. NORTH 00° 08' 11" EAST, 210.40 FEET, ALONG SAID PARALLEL LINE, TO THE **TRUE POINT OF BEGINNING**.

EXCEPT THEREFROM UNTO, TIDEWATER ASSOCIATED OIL COMPANY, ITS SUCCESSORS AND ASSIGNS IN DEED RECORDED FEBRUARY 25, 1947 ION BOOK 24243 PAGE 423, OFFICIAL RECORDS, ALL MINERALS, INCLUDING BUT NOT LIMITED TO HYDRO CARBONACEOUS SUBSTANCES, TOGETHER WITH THE RIGHT TO MINE, EXTRACT, RECOVER AND REMOVE THE SAME; PROVIDED, HOWEVER, AND GRANTOR SO COVENANTS, THAT GRANTOR, ITS SUCCESSORS AND ASSIGNS, EXCEPT BY PERMISSION OF GRANTEE, ITS SUCCESSORS OR ASSIGNS, WILL NEVER ENTER UPON THE SURFACE OF SAID LANDS FOR THE PURPOSE OF MINING, EXTRACTING, REMOVING, OR RECOVERING SAID MINERALS, IT BEING EXPRESSLY COVENANTED AND AGREED, HOWEVER, THAT GRANTOR, ITS SUCCESSORS AND ASSIGNS, SHALL HAVE THE RIGHT TO MINE, EXTRACT, RECOVER AND REMOVE SAID MINERALS BY MEANS OF DIRECTIONAL OR SUBSURFACE DRILLING OR ANY OTHER RECOVERY METHOD, WHETHER SIMILAR OR DISSIMILAR, SO LONG AS THE SURFACE OF SAID LANDS IS NOT OCCUPIED OR USED, OR ITS SUPPORT MATERIALLY IMPAIRED,

CONTINUED ON NEXT PAGE

15

ALSO FROM THAT PORTION OF SAID LAND LYING EASTERLY OF THE FOLLOWING DESCRIBED LINE; BEGINNING AT A POINT IN THE NORTHERLY LINE OF THE SOUTHEAST QUARTER OF SAID SECTION 34, DISTANT THEREON SOUTH 89 DEGREES 59'12" EAST 1322.40 FEET FROM THE NORTHWEST CORNER OF SAID SOUTHEAST QUARTER OF SAID SECTION, SAID POINT OF BEGINNING BEING THE NORTHWEST CORNER OF THE EAST HALF OF SAID SOUTHEAST QUARTER OF SAID SECTION; THENCE ALONG THE WESTERLY LINE OF SAID EAST HALF OF SAID SOUTHEAST QUARTER OF SAID SECTION, SOUTH 0 DEGREES 2'22" EAST 2590.40 FEET TO THE NORTHERLY LINE OF CENTURY BOULEVARD, 100 FEET WIDE.

ALSO EXCEPT THEREFROM UNTO MANCHESTER AVENUE COMPANY, A CALIFORNIA CORPORATION, BY DEED RECORDED AUGUST 31, 1956 IN BOOK 52179 PAGE 412, OFFICIAL RECORDS, AN UNDIVIDED 28/200 OF ONE PERCENT OF ALL MINERALS, OIL, GAS AND OTHER HYDROCARBON SUBSTANCES OR THE PROCEEDS THEREFROM IN AND UNDER OR THAT MAY BE PRODUCED OR SAVED FROM THAT PORTION OF SAID LAND LYING NORTHERLY OF A LINE PARALLEL WITH AND 1320 FEET MEASURED SOUTHERLY AT RIGHT ANGLES FROM THE NORTHERLY LINE OF SAID SECTION 34.

ALSO EXCEPT ALL SUBSURFACE OIL, GAS, CASINGHEARD GAS AND OTHER HYDROCARBON AND OTHER GASEOUS SUBSTANCES LOCATED ON SAID PROPERTY, AS GRANTED TO HOLLYWOOD PARK OPERATING COMPANY, A DELAWARE CORPORATION, IN A DEED RECORDED MAY 18, 1982 AS INSTRUMENT NO. 82-511580.

ALSO EXCEPT THEREFROM UNTO MASON LETTEAU, F.T. HINTON AND JOHN R. MAC FADEN CONSTITUTING THE BOARD OF TRUSTEES OF THE ENDOWMENT CARE FUND OF INGLEWOOD PARK CEMETERY ASSOCIATION, IN DEED RECORDED MARCH 18, 1964 IN BOOK D2398 PAGE 795, OFFICIAL RECORDS, ALL MINERALS, OIL, GAS AND OTHER HYDROCARBON SUBSTANCES LYING IN OR BELOW A DEPTH OF 500 FEET AND WITHOUT RIGHT OF SURFACE ENTRY ON THAT PORTION OF SAID LAND LYING NORTHERLY OF A LINE PARALLEL WITH AND 1320 FEET SOUTHERLY MEASURED AT RIGHT ANGLES FROM THE NORTHERLY LINE OF SAID SECTION 34.

A PORTION OF APN: 4025-011-028 AND 4025-011-029

CONTAINING: 174,213 SQUARE FEET, OR 3.999 ACRES MORE OR LESS, SEE ATTACHED

SUBJECT TO: ALL COVENANTS, RIGHTS, RIGHTS-OF-WAY AND EASEMENTS OF RECORD.

PREPARED BY ME OR UNDER MY SUPERVISION.

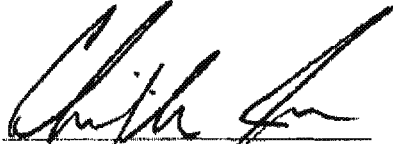
CHRISTOPHER JONES, L.S. 8193
EXPIRES: 12-31-2010

11/05/09
DATE



12

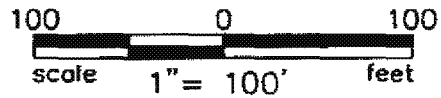
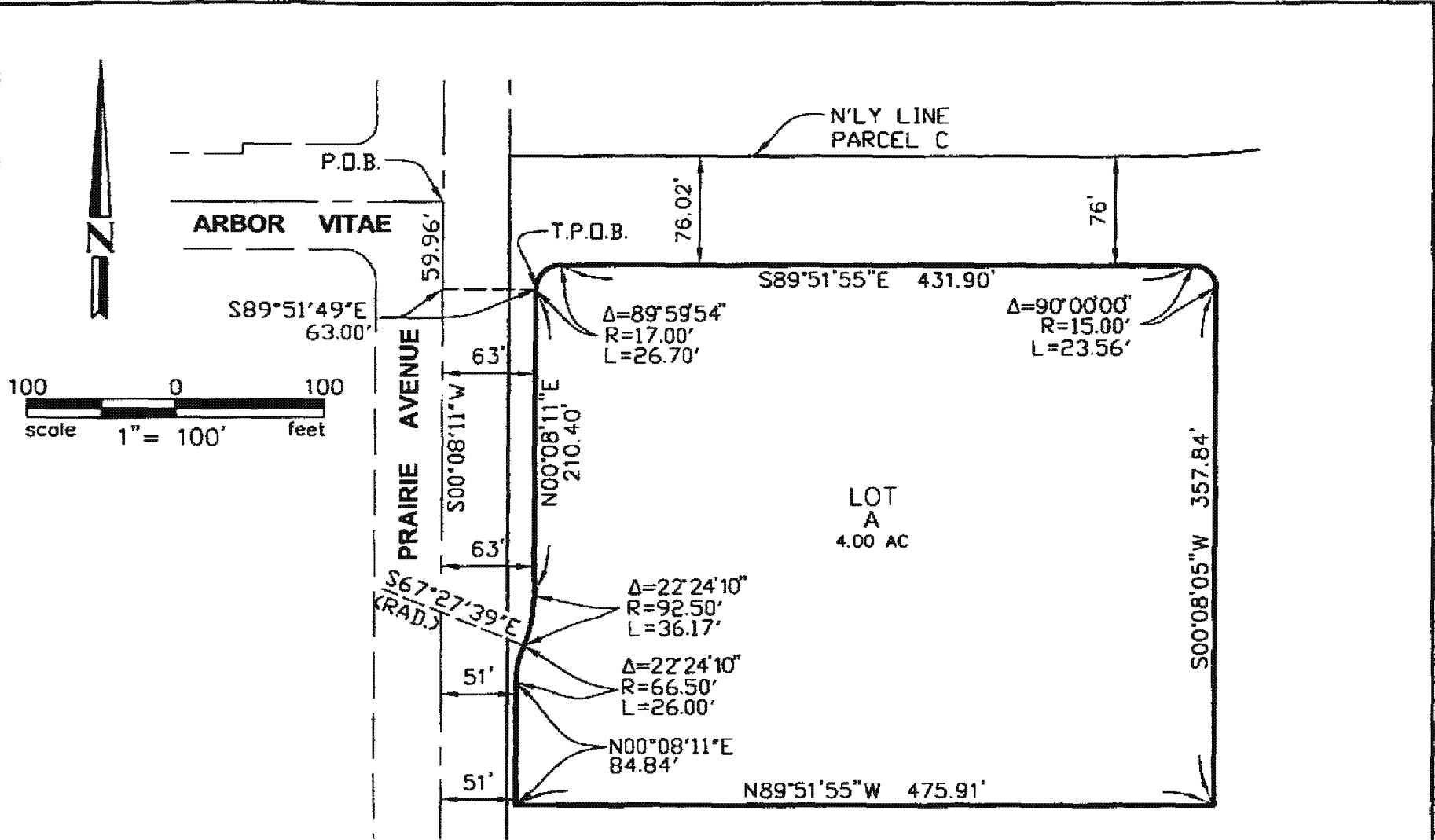

LEGEND

- P.O.B - POINT OF BEGINNING
- T.P.O.B - TRUE POINT OF BEGINNING

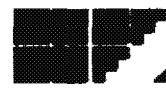

Hall & Foreman, Inc.

Engineering · Planning · Surveying

25152 SPRINGFIELD COURT, SUITE 350 · SANTA CLARITA, CA 91355 · 661-284-7400

Job Number:	SS-070119
Date:	11-04-2009
Scale:	1"=100'
Sheet 3 of	3 Sheets

Surveying: 11/04/09 11:19 AM Mapping: 07/18/2009 Layout: 10/22/09 Plot: 03_01c.dwg
 A-legal.plt 11-04-09
 User: jforbes
 Plot Date: 11/04/09 1:03pm

17

EXHIBIT "B"
LEGAL DESCRIPTION
FUTURE STREET EASEMENT

THAT PORTION OF PARCEL "C", AS SHOWN ON PARCEL MAP NO. 25640, IN THE CITY OF INGLEWOOD, COUNTY OF LOS ANGELES, STATE OF CALIFORNIA, AS RECORDED IN BOOK 289, PAGES 53-61 OF PARCEL MAPS, RECORDS OF SAID COUNTY, BETTER DESCRIBED AS FOLLOWS:

BEGINNING AT THE CENTERLINE INTERSECTION OF CENTURY BOULEVARD AND PRAIRIE AVENUE AS SHOWN ON SAID MAP, THENCE NORTH 00°08'11" EAST (SHOWN AS NORTH 00°00'14" WEST ON SAID MAP), 2225.07' ALONG SAID CENTERLINE OF PRAIRIE AVENUE, THENCE PERPENDICULAR TO SAID CENTERLINE, SOUTH 89°51'49" EAST, 45.00 FEET, TO THE POINT OF INTERSECTION OF THE EASTERLY RIGHT OF WAY OF SAID PRAIRIE AVENUE WITH THE SOUTHERLY LINE OF THE PROPOSED CIVIC CENTER LOT AS SHOWN ON THE VESTING TENTATIVE TRACT MAP NO. 69906, SAID POINT ALSO BEING THE **TRUE POINT OF BEGINNING**, THENCE THE FOLLOWING NUMBERED COURSES:

1. NORTH 00°08'11" EAST, 372.84 FEET, ALONG SAID EASTERLY RIGHT OF WAY, TO THE NORTHERLY LINE OF SAID PROPOSED CIVIC CENTER LOT;
2. SOUTH 89°51'55" EAST, 35.00 FEET, ALONG SAID NORTHERLY LINE, TO A POINT OF CUSP WITH A CURVE CONCAVE SOUTHEASTERLY, HAVING A RADIUS OF 17.00 FEET;
3. SOUTHWESTERLY, ALONG SAID CURVE, THROUGH A CENTRAL ANGLE OF 89°59'54", AN ARC DISTANCE OF 26.70 FEET, TO THE BEGINNING OF A TANGENT LINE, SAID LINE BEING PARALLEL WITH, AND 63.00 FEET EASTERLY OF, THE CENTERLINE OF SAID PRAIRIE AVENUE;
4. SOUTH 00°08'11" WEST, 210.40 FEET, ALONG SAID PARALLEL LINE, TO THE BEGINNING OF A TANGENT CURVE, CONCAVE WESTERLY, HAVING A RADIUS OF 92.50 FEET;
5. SOUTHERLY, ALONG SAID CURVE, THROUGH A CENTRAL ANGLE OF 22°24'10", AN ARC DISTANCE OF 36.17 FEET, TO A REVERSE CURVE, CONCAVE EASTERLY, HAVING A RADIUS OF 66.50 FEET;
6. SOUTHERLY, ALONG SAID CURVE, THROUGH A CENTRAL ANGLE OF 22°24'10", AN ARC DISTANCE OF 26.00 FEET, TO THE BEGINNING OF A TANGENT LINE, SAID LINE BEING PARALLEL WITH, AND 51.00 FEET EASTERLY OF, THE CENTERLINE OF SAID PRAIRIE AVENUE;
7. SOUTH 00°08'11" WEST, 84.84 FEET, ALONG SAID PARALLEL LINE, TO SAID SOUTHERLY LINE OF THE PROPOSED CIVIC CENTER LOT;
8. NORTH 89°51'55" WEST, 6.00 FEET, ALONG SAID SOUTHERLY LINE, TO THE **TRUE POINT OF BEGINNING**.

CONTAINING: 5,411 SQUARE FEET, OR 0.124 ACRES MORE OR LESS, SEE ATTACHED

SUBJECT TO: ALL COVENANTS, RIGHTS, RIGHTS-OF-WAY, EASEMENTS OF RECORD AND ANY FUTURE STREET DEDICATIONS.

PREPARED UNDER MY SUPERVISION:

 9/23/09
 DANIAL R. MARTIN, L.S. 5860 DATE
 LICENSE EXPIRES: 12/31/10





LINE TABLE		
NO.	BEARING	LENGTH
L1	S 89°51'49" E	45.00'
L2	S 89°51'55" E	35.00'
L3	S 00°08'11" W	84.84'
L4	N 89°51'55" W	6.00'

ARC TABLE			
NO.	DELTA	RADIUS	LENGTH
C1	89°59'54"	17.00'	26.70'
C2	22°24'10"	92.50'	36.17'
C3	22°24'10"	66.50'	26.00'

LEGEND:

- P.O.B - POINT OF BEGINNING
- T.P.O.B. - TRUE POINT OF BEGINNING
- N'LY - NORTHERLY
- S'LY - SOUTHERLY

DENOTES EASEMENT AREA

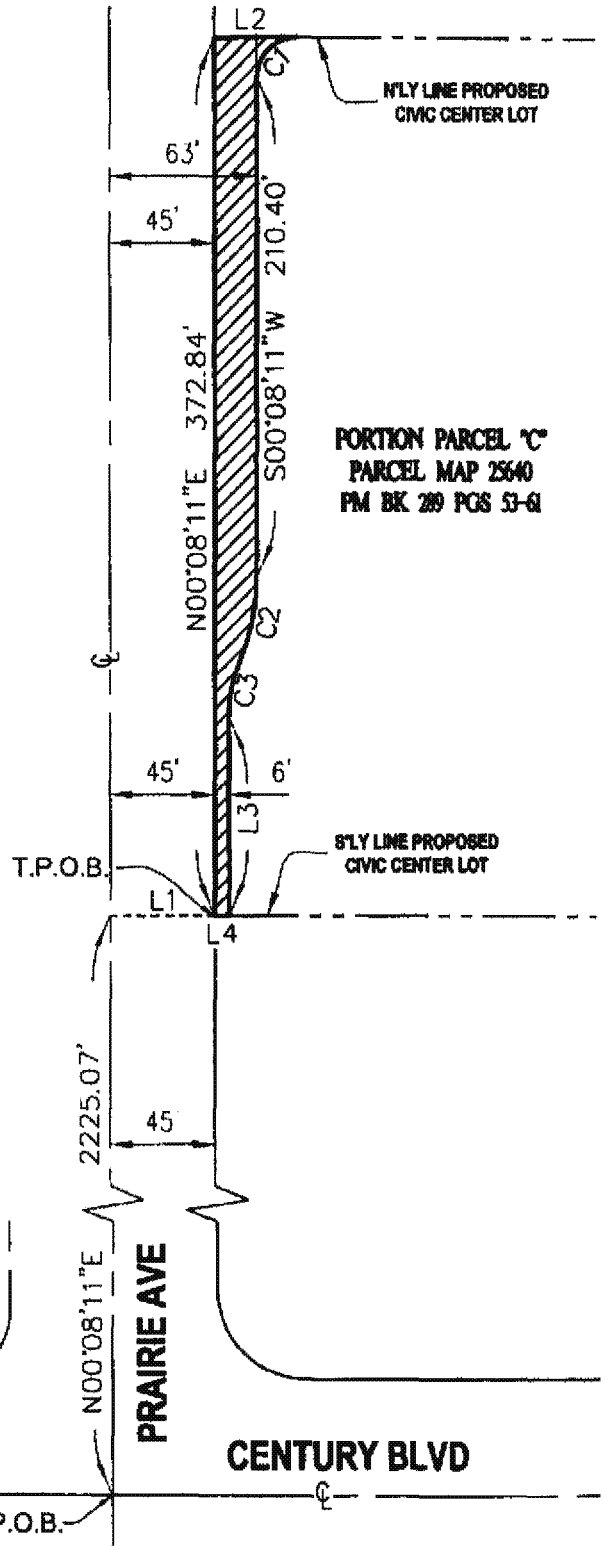

TITLE:
*EASEMENT FOR
 FUTURE STREET PURPOSES*

Hall & Foreman, Inc.
 Civil Engineering • Planning • Surveying • Public Works
 25152 Springfield Ct., Ste. 350 • Santa Clarita, CA 91355 • 861.284.7400

DATE OF PREPARATION: 09/22/09

Drawing Name: C:\070119\Working\070119\0000\Vegeta\02_SHEET_2\EASEMENT\02_SHEET_2\EASEMENT.dwg Date: 09/22/09 10:23:51 AM SHEET 1000-001

EXHIBIT "C"

ENCUMBRANCES AND OTHER MATTERS OF RECORD

- 1. A lien of supplemental taxes, if any, assessed pursuant to the provisions of Chapter 3.5 (Commencing with Section 75) of the Revenue and Taxation Code of the State of California.
- 2. Water rights, claims or title to water, whether or not disclosed by the public records.
- 3. A covenant contained in the Grant Deed dated June 18, 1951 by and between Hollywood Turf Club, a California Corporation as Grantor and Superior Building Company, a copartnership, consisting of Albert Gersten and Myron P. Beck, their heirs and assigns wherein Hollywood Park Turf Club, a California corporation, conveyed lands to various grantees, in which deeds Hollywood Turf Club agrees not to consent to any surface entry by Tidewater Associated Oil Company, for the purpose of mining, extracting, removing or recovering materials from that portion of said land lying Easterly of the following described line:

Beginning at a point in the Northerly line of the Southeast quarter of said Section 34, distant thereon South 89 degrees 59'12" east 1322.40 feet from the Northwest corner of said Southeast quarter of said Section, said point of beginning being the Northwest corner of the East half of said Southeast quarter of said Section; thence along the westerly line of the East one-half of said Southwest one-quarter of said Section, South 0 degrees 2'22" east 2590.40 feet to the northerly line of Century Boulevard, 10 feet wide, one of such deeds recorded June 29, 1951 as Instrument No. 985 in Book 36648, Page 16, Official Records.

- 4. An easement to lay, construct, maintain, operate, repair, renew, from time to time, change the size of (but not to increase such size beyond 12 inches in diameter), and remove a pipeline for transportation of gas and incidental purposes in the document recorded March 19, 1948 as Instrument No. 2340, in Book 26745, Page 81, of Official Records.
- 5. Matters contained in that certain document entitled "Merged Inglewood Redevelopment Project Statement" dated June 26, 2007, recorded August 1, 2007 as Instrument No. 20071823536, of Official Records, and recorded August 6, 2009 as Instrument No. 20091207392 of Official Records.
- 6. Matters contained in that certain document entitled "Development Agreement" dated August 7, 2009, executed by and between City of Inglewood, a municipal corporation and Hollywood Park Land Company, LLC recorded September 10, 2009 as Instrument No. 20091387150, of Official Records.

20

EXHIBIT "D"
LEGAL DESCRIPTION

PARCEL "C" OF PARCEL MAP NO. 25640, IN THE CITY OF INGLEWOOD, COUNTY OF LOS ANGELES, STATE OF CALIFORNIA, AS PER MAP FILED IN BOOK 289, PAGES 53 TO 61 INCLUSIVE OF PARCEL MAPS, IN THE OFFICE OF THE COUNTY RECORDER OF SAID COUNTY.

THE ABOVE REFERENCED MAP BEING AFFECTED BY THAT CERTAIN CERTIFICATE OF CORRECTION RECORDED JUNE 28, 2000 AS INSTRUMENT NO. 00-0993688 OF OFFICIAL RECORDS.

EXCEPT THEREFROM, UNTO TIDEWATER ASSOCIATED OIL COMPANY, ITS SUCCESSORS AND ASSIGNS, IN DEED RECORDED FEBRUARY 25, 1947 IN BOOK 24243, PAGE 423, OFFICIAL RECORDS, ALL MINERALS, INCLUDING BUT NOT LIMITED TO HYDRO CARBONACEOUS SUBSTANCES, TOGETHER WITH THE RIGHT TO MINE, EXTRACT, RECOVER AND REMOVE THE SAME; SUBJECT, HOWEVER TO THE PROVISIO AND COVENANTS THERETO CONTAINED.

ALSO EXCEPT THEREFROM, UNTO MANCHESTER AVENUE COMPANY, A CALIFORNIA CORPORATION, BY DEED RECORDED AUGUST 31, 1956 IN BOOK 52179, PAGE 412, OFFICIAL RECORDS, AN UNDIVIDED 28/200 OF ONE PERCENT OF ALL MINERALS, OIL, GAS AND OTHER HYDROCARBON SUBSTANCES OR THE PROCEEDS THEREFROM, IN AND UNDER OR THAT MAY BE PRODUCED OR SAVED FROM THAT PORTION OF SAID LAND LYING NORTHERLY OF A LINE PARALLEL WITH AND 1320 FEET SOUTHERLY, MEASURED AT RIGHT ANGLES FROM THE NORTHERLY LINE OF SAID SECTION 34.

ALSO EXCEPT ALL SUBSURFACE OIL, GAS, CASINGHEAD GAS AND OTHER HYDROCARBON AND OTHER GASEOUS SUBSTANCES LOCATED ON SAID PROPERTY, AS GRANTED TO HOLLYWOOD PARK OPERATING COMPANY, A DELAWARE CORPORATION, IN A DEED RECORDED MAY 18, 1982 AS INSTRUMENT NO. 82-511580.

ALSO EXCEPT THEREFROM UNTO MASON LETTEAN, F.T. HINTON AND JOHN R. MAC FADEN CONSTITUTING THE BOARD OF TRUSTEES OF THE ENDOWMENT CARE FUND OF INGLEWOOD PARK CEMETERY ASSOCIATION, IN DEED RECORDED MARCH 18, 1964 IN BOOK D2398 PAGE 795, OFFICIAL RECORDS, ALL MINERALS, OIL, GAS AND OTHER HYDROCARBON SUBSTANCES LYING IN OR BELOW A DEPTH OF 500 FEET AND WITHOUT RIGHT OF SURFACE ENTRY ON THAT PORTION OF SAID LAND LYING NORTHERLY OF A LINE PARALLEL WITH AND 1320 FEET SOUTHERLY, MEASURED AT RIGHT ANGLES FROM THE NORTHERLY LINE OF SAID SECTION 34.

EXCLUDING THEREFROM, LOT "A", BEING A PORTION OF SAID PARCEL "C", BETTER DESCRIBED AS FOLLOWS:

BEGINNING AT THE CENTERLINE INTERSECTION OF ARBOR VITAE AND PRAIRIE AVENUE, AS SHOWN ON SAID PARCEL MAP, THENCE THE FOLLOWING NUMBERED COURSES:

- 1 SOUTH 00° 08' 11" WEST, 59.96 FEET ALONG THE CENTERLINE OF PRAIRIE AVENUE,
2. SOUTH 89° 51' 49" EAST, 63.00 FEET, PERPENDICULAR TO SAID CENTERLINE, TO THE TRUE POINT OF BEGINNING, SAID POINT ALSO BEING THE BEGINNING OF A NON-TANGENT CURVE, CONCAVE SOUTHEASTERLY, HAVING A RADIUS OF 17.00 FEET,

u

3. NORTHEASTERLY ALONG SAID CURVE, THROUGH A CENTRAL ANGLE OF 89° 59' 54", AN ARC DISTANCE OF 26.70 FEET, TO THE BEGINNING OF A TANGENT LINE,
4. SOUTH 89° 51' 55" EAST, 431.90 FEET, ALONG SAID TANGENT LINE, TO THE BEGINNING OF A TANGENT CURVE, CONCAVE SOUTHWESTERLY, HAVING A RADIUS OF 15.00 FEET,
5. SOUTHEASTERLY ALONG SAID CURVE, THROUGH A CENTRAL ANGLE OF 90° 00' 00", AN ARC DISTANCE OF 23.56 FEET, TO THE BEGINNING OF A TANGENT LINE,
6. SOUTH 00° 08' 05" WEST, 357.84 FEET, ALONG SAID TANGENT LINE,
7. NORTH 89° 51' 55" WEST, 475.91 FEET, TO THE BEGINNING OF A LINE THAT IS PARALLEL WITH, AND 51.00 FEET EASTERLY OF THE CENTERLINE OF SAID PRAIRIE AVENUE,
8. NORTH 00° 08' 11" EAST, 84.84 FEET, ALONG SAID PARALLEL LINE, TO THE BEGINNING OF A TANGENT CURVE, CONCAVE SOUTHEASTERLY, HAVING A RADIUS OF 66.50 FEET,
9. NORTHEASTERLY ALONG SAID CURVE, THROUGH A CENTRAL ANGLE OF 22° 24' 10", AN ARC DISTANCE OF 26.00 FEET, TO THE BEGINNING OF A REVERSE CURVE, CONCAVE NORTHWESTERLY, HAVING A RADIUS OF 92.50 FEET, A RADIAL LINE TO SAID CURVE BEARS SOUTH 67° 27' 39" EAST,
10. NORTHEASTERLY ALONG SAID CURVE, THROUGH A CENTRAL ANGLE OF 22° 24' 10", AN ARC DISTANCE OF 36.17 FEET, TO THE BEGINNING OF A TANGENT LINE, SAID TANGENT LINE BEING PARALLEL WITH, AND 63.00 FEET EASTERLY OF, THE CENTERLINE OF SAID PRAIRIE AVENUE,
11. NORTH 00° 08' 11" EAST, 210.40 FEET, ALONG SAID PARALLEL LINE, TO THE TRUE POINT OF BEGINNING.

CONTAINING: 10,209,018.00 SQUARE FEET, OR 234.367 ACRES MORE OR LESS, SEE ATTACHED.

SUBJECT TO: ALL COVENANTS, RIGHTS, RIGHTS-OF-WAY AND EASEMENTS OF RECORD.

PREPARED UNDER MY SUPERVISION:

Daniel R. Martin 9/23/09

 DANIAL R. MARTIN, L.S. 5860 DATE
 LICENSE EXPIRES: 12/31/10



ARBOR
VITAE

LOT A
(NOT A PART)

PRAIRIE AVENUE

PARCEL "C"
PARCEL MAP NO. 25640
PM BK 289 PGS 53-61

CENTURY BLVD.



NOT TO SCALE



Hall & Foreman, Inc.

Engineering • Planning • Surveying

25152 SPRINGFIELD COURT, SUITE 350 • SANTA CLARITA, CA 91355 • 661-284-7400

Job Number:	SS.070119
Date:	09-22-2009
Scale:	NO SCALE
Sheet 2 of	
2 Sheets	

Drawing Name: C:\070119\Surveying\070119_0000\Mapan\03...SITE EXCLUSION LOT A, B, C, D, E, F, G, H, I, J, K, L, M, N, O, P, Q, R, S, T, U, V, W, X, Y, Z, AA, AB, AC, AD, AE, AF, AG, AH, AI, AJ, AK, AL, AM, AN, AO, AP, AQ, AR, AS, AT, AU, AV, AW, AX, AY, AZ, BA, BB, BC, BD, BE, BF, BG, BH, BI, BJ, BK, BL, BM, BN, BO, BP, BQ, BR, BS, BT, BU, BV, BW, BX, BY, BZ, CA, CB, CC, CD, CE, CF, CG, CH, CI, CJ, CK, CL, CM, CN, CO, CP, CQ, CR, CS, CT, CU, CV, CW, CX, CY, CZ, DA, DB, DC, DD, DE, DF, DG, DH, DI, DJ, DK, DL, DM, DN, DO, DP, DQ, DR, DS, DT, DU, DV, DW, DX, DY, DZ, EA, EB, EC, ED, EE, EF, EG, EH, EI, EJ, EK, EL, EM, EN, EO, EP, EQ, ER, ES, ET, EU, EV, EW, EX, EY, EZ, FA, FB, FC, FD, FE, FF, FG, FH, FI, FJ, FK, FL, FM, FN, FO, FP, FQ, FR, FS, FT, FU, FV, FW, FX, FY, FZ, GA, GB, GC, GD, GE, GF, GG, GH, GI, GJ, GK, GL, GM, GN, GO, GP, GQ, GR, GS, GT, GU, GV, GW, GX, GY, GZ, HA, HB, HC, HD, HE, HF, HG, HH, HI, HJ, HK, HL, HM, HN, HO, HP, HQ, HR, HS, HT, HU, HV, HW, HX, HY, HZ, IA, IB, IC, ID, IE, IF, IG, IH, II, IJ, IK, IL, IM, IN, IO, IP, IQ, IR, IS, IT, IU, IV, IW, IX, IY, IZ, JA, JB, JC, JD, JE, JF, JG, JH, JI, JJ, JK, JL, JM, JN, JO, JP, JQ, JR, JS, JT, JU, JV, JW, JX, JY, JZ, KA, KB, KC, KD, KE, KF, KG, KH, KI, KJ, KK, KL, KM, KN, KO, KP, KQ, KR, KS, KT, KU, KV, KW, KX, KY, KZ, LA, LB, LC, LD, LE, LF, LG, LH, LI, LJ, LK, LL, LM, LN, LO, LP, LQ, LR, LS, LT, LU, LV, LW, LX, LY, LZ, MA, MB, MC, MD, ME, MF, MG, MH, MI, MJ, MK, ML, MM, MN, MO, MP, MQ, MR, MS, MT, MU, MV, MW, MX, MY, MZ, NA, NB, NC, ND, NE, NF, NG, NH, NI, NJ, NK, NL, NM, NN, NO, NP, NQ, NR, NS, NT, NU, NV, NW, NX, NY, NZ, OA, OB, OC, OD, OE, OF, OG, OH, OI, OJ, OK, OL, OM, ON, OO, OP, OQ, OR, OS, OT, OU, OV, OW, OX, OY, OZ, PA, PB, PC, PD, PE, PF, PG, PH, PI, PJ, PK, PL, PM, PN, PO, PP, PQ, PR, PS, PT, PU, PV, PW, PX, PY, PZ, QA, QB, QC, QD, QE, QF, QG, QH, QI, QJ, QK, QL, QM, QN, QO, QP, QQ, QR, QS, QT, QU, QV, QW, QX, QY, QZ, RA, RB, RC, RD, RE, RF, RG, RH, RI, RJ, RK, RL, RM, RN, RO, RP, RQ, RR, RS, RT, RU, RV, RW, RX, RY, RZ, SA, SB, SC, SD, SE, SF, SG, SH, SI, SJ, SK, SL, SM, SN, SO, SP, SQ, SR, SS, ST, SU, SV, SW, SX, SY, SZ, TA, TB, TC, TD, TE, TF, TG, TH, TI, TJ, TK, TL, TM, TN, TO, TP, TQ, TR, TS, TT, TU, TV, TW, TX, TY, TZ, UA, UB, UC, UD, UE, UF, UG, UH, UI, UJ, UK, UL, UM, UN, UO, UP, UQ, UR, US, UT, UY, UZ, VA, VB, VC, VD, VE, VF, VG, VH, VI, VJ, VK, VL, VM, VN, VO, VP, VQ, VR, VS, VT, VU, VV, VW, VX, VY, VZ, WA, WB, WC, WD, WE, WF, WG, WH, WI, WJ, WK, WL, WM, WN, WO, WP, WQ, WR, WS, WT, WU, WV, WW, WX, WY, WZ, XA, XB, XC, XD, XE, XF, XG, XH, XI, XJ, XK, XL, XM, XN, XO, XP, XQ, XR, XS, XT, XU, XV, XW, XX, XY, XZ, YA, YB, YC, YD, YE, YF, YG, YH, YI, YJ, YK, YL, YM, YN, YO, YP, YQ, YR, YS, YT, YU, YV, YW, YX, YY, YZ, ZA, ZB, ZC, ZD, ZE, ZF, ZG, ZH, ZI, ZJ, ZK, ZL, ZM, ZN, ZO, ZP, ZQ, ZR, ZS, ZT, ZU, ZV, ZW, ZX, ZY, ZZ

22

EXHIBIT "E"

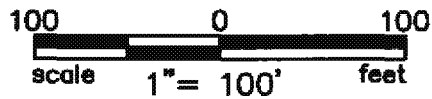
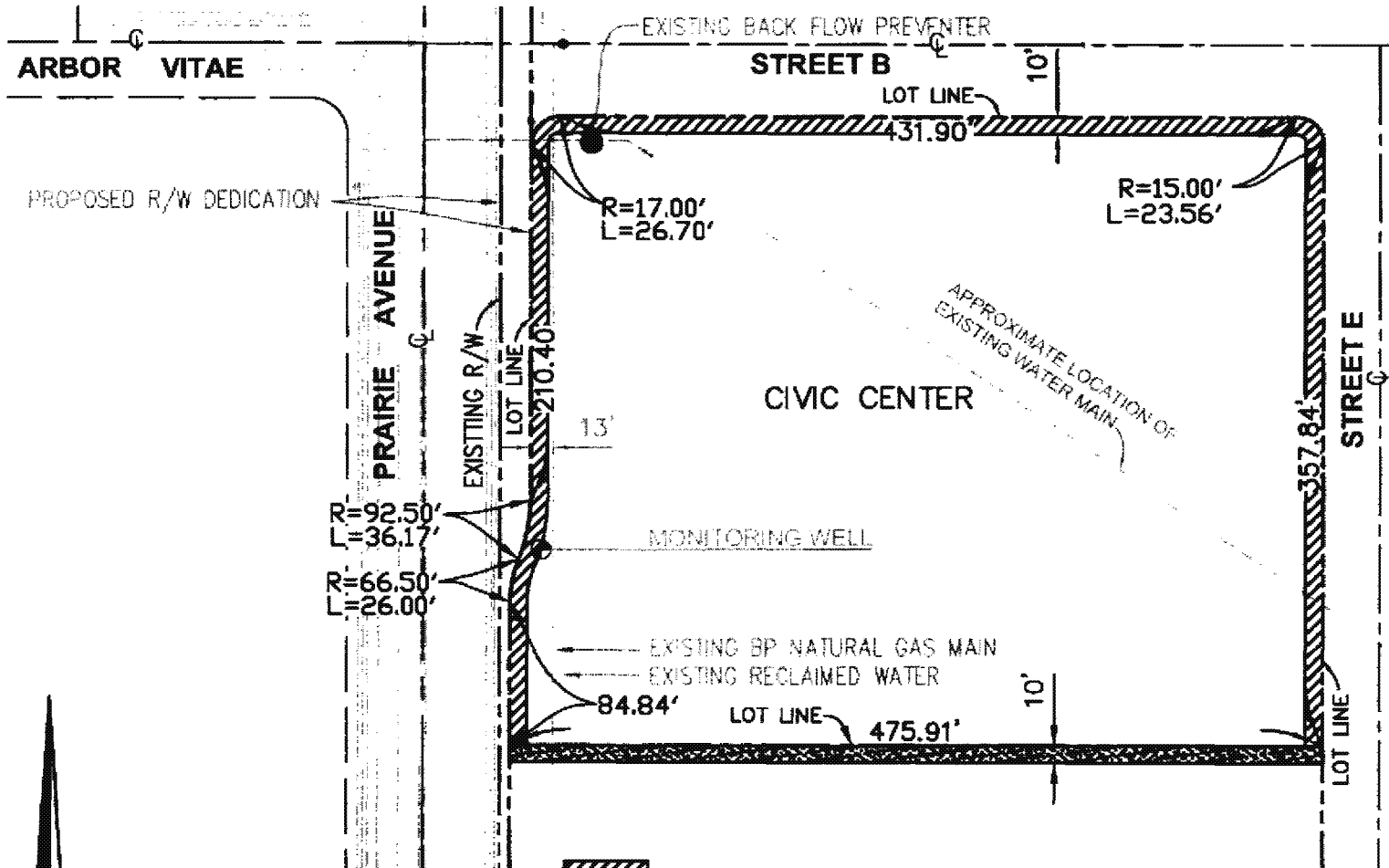

- 10' WIDE GRANTOR CONSTRUCTION & SLOPE EASEMENT
- 10' WIDE GRANTEE CONSTRUCTION & SLOPE EASEMENT

Hall & Foreman, Inc.
 Engineering · Planning · Surveying
 25152 SPRINGFIELD COURT, SUITE 350 · SANTA CLARITA, CA 91355 · 661-284-7400

Job Number:	SS.070118
Date:	11-06-2008
Scale:	1"=100'
Sheet 1 of	1 Sheets

Drawing Name: C:\Documents and Settings\khamilton\Desktop\Exhibit E\Exhibit E.dwg
 Last Opened: Nov 07, 2008 - 7:26am by: khamilton

Handwritten initials

EXHIBIT "F"

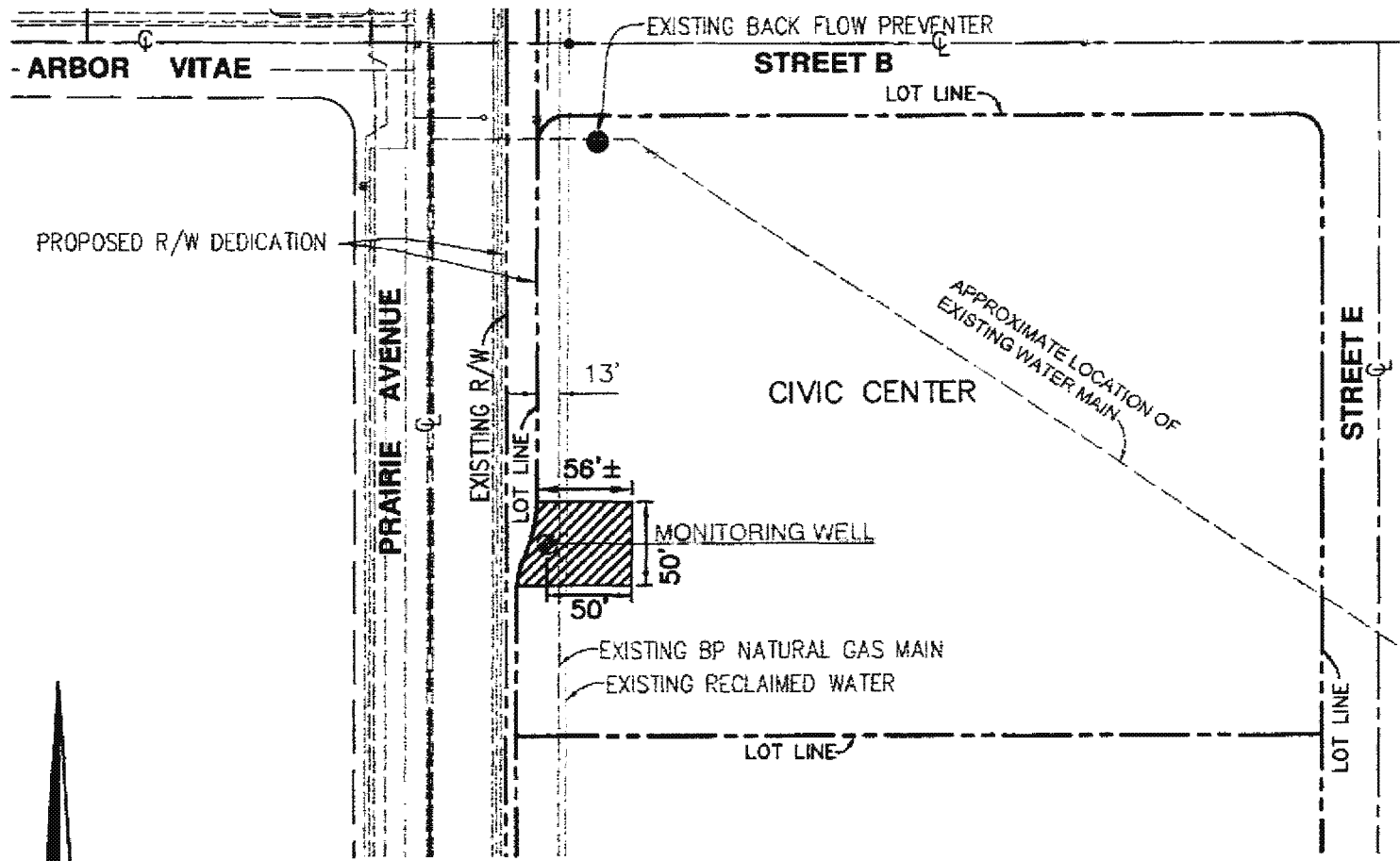

MONITORING WELL EASEMENT

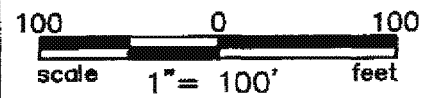

Hall & Foreman, Inc.
 Engineering • Planning • Surveying
 25152 SPRINGFIELD COURT, SUITE 350 • SANTA CLARITA, CA 91365 • 661-284-7400

Job Number:	SS.070119
Date:	09-21-2009
Scale:	1"=100'
Sheet 1 of	1 Sheets

Working Files: L:\07119\07119-000\Projects\07119-000\Civic Center easement exhibits 08-21-09\Civic Center-01
 Worksheet: 11_08-21-09.dwg
 User: gregory Sep 22, 2009 11:41 AM
 Plot by: Theston

12

EXHIBIT "G"

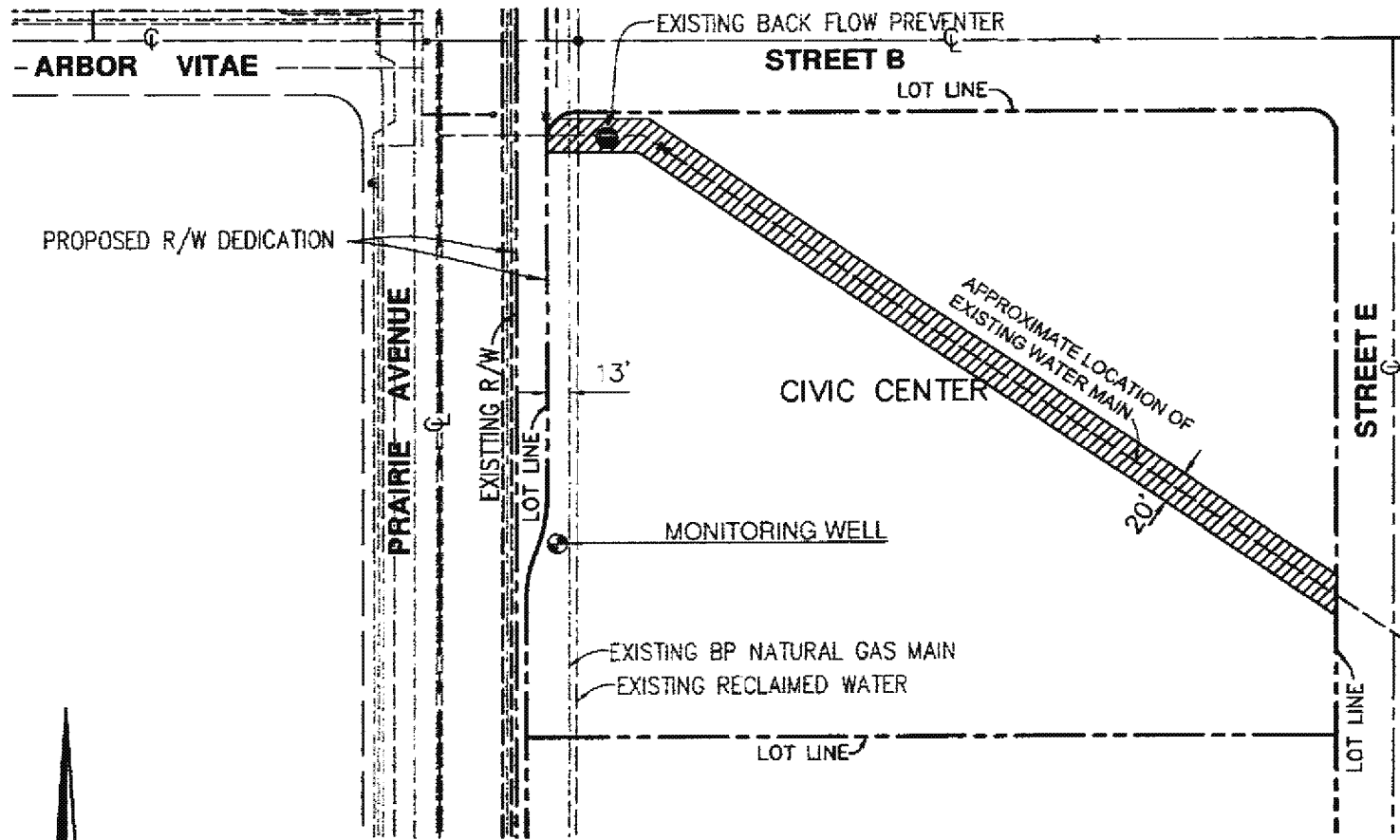

 20' DOMESTIC WATER MAINTENANCE EASEMENT

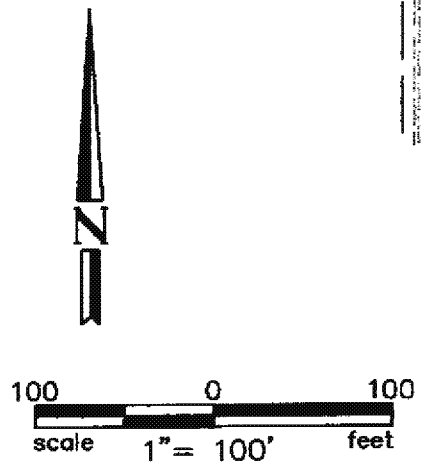

Hall & Foreman, Inc.
Engineering · Planning · Surveying
 25152 SPRINGFIELD COURT, SUITE 350 • SANTA CLARITA, CA 91355 • 661-284-7400

Job Number:	SS.070119
Date:	09-21-2009
Scale:	1"=100'
Sheet 1 of	1 Sheets

Drawing Date: 09/21/09 09:07:19 - 000 (C:\Users\jhall\Documents\2009\22-Civic Center easement exhibits 09-21-09\02a-Dwgs-LOT-1.dwg) 11:59:21 AM
 Last Updated: Sep 22, 2009 11:59:21 AM by: jhall

75

EXHIBIT "H"

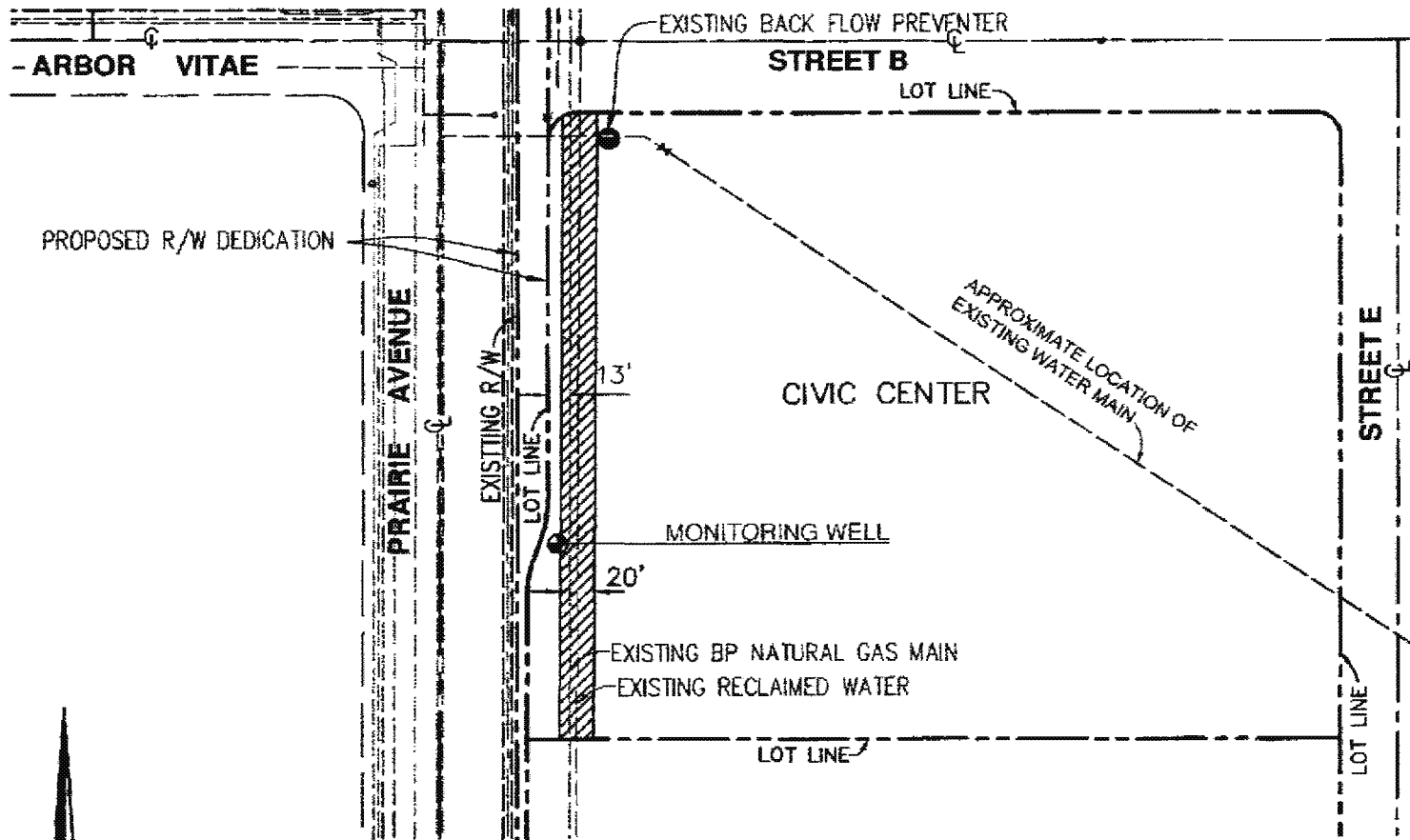

 20' RECLAIMED WATER MAINTENANCE EASEMENT

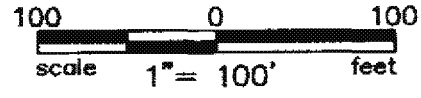

Hall & Foreman, Inc.
Engineering · Planning · Surveying
 25152 SPRINGFIELD COURT, SUITE 350 • SANTA CLARITA, CA 91355 • 661-284-7400

Job Number:	SS.070119
Date:	09-21-2009
Scale:	1"=100'
Sheet 1 of	1 Sheets

Drawing Name: L:\070119\070119-000\Exhibit\2008\22_Civic Center easement exhibits 09-21-09\014a Center-1.dwg
 User: J. J. J. J. J.
 Date: 09/21/09
 Plot Operator: Sep 22, 2009 4:48pm by: jrbkbb

26

EXHIBIT "I"

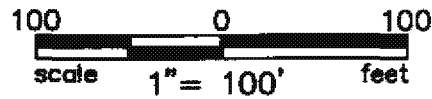
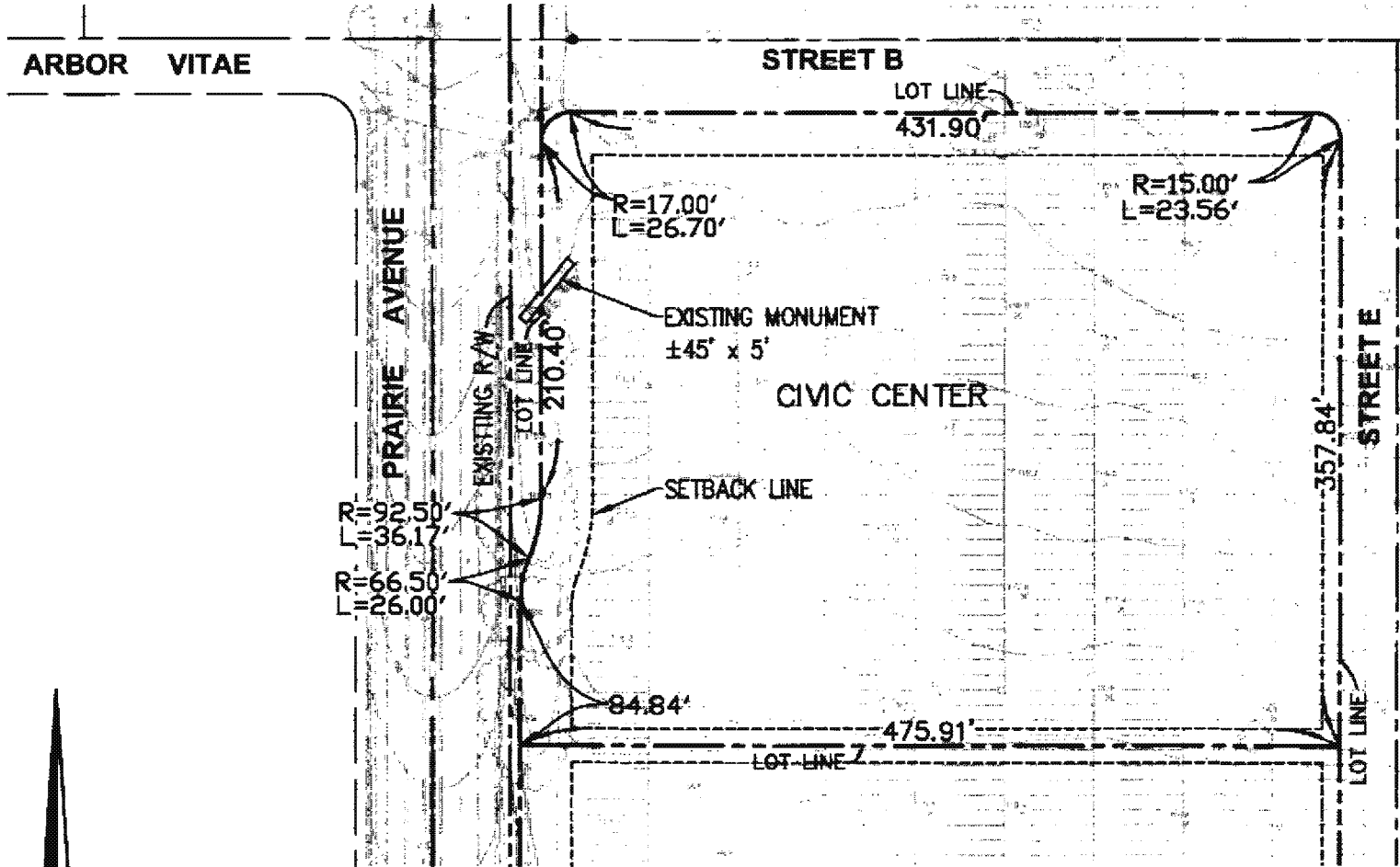

 **Hall & Foreman, Inc.**
Engineering • Planning • Surveying
 25152 SPRINGFIELD COURT, SUITE 350 • SANTA CLARITA, CA 91355 • 661-284-7400

Job Number:	SS.070119
Date:	10-21-2009
Scale:	1"=100'
Sheet 1 of	1 Sheets

11-21-09 11:58am by H:\user\j...
 11-21-09 11:58am by H:\user\j...
 11-21-09 11:58am by H:\user\j...
 11-21-09 11:58am by H:\user\j...

12

18

CERTIFICATE OF ACCEPTANCE

(PURSUANT TO CA. GOVT CODE SECTION 27281)

This is to certify that the interest in the Land (described in Exhibit "A") conveyed by the GRANT DEED AND IRREVOCABLE OFFER OF DEDICATION dated January 20, 2010 from Hollywood Park Land Company, LLC, a Delaware limited liability company (the "Grantor"), to the City of Inglewood, a municipal corporation (the "Grantee"), is hereby accepted by order of the Inglewood City Council on January 26, 2010 (or by the undersigned officer or agent on behalf of the Inglewood City Council pursuant to authority conferred by resolution of the Inglewood City Council adopted on N/A), and the Grantee consents to recordation thereof by its duly authorized officer.

Dated: 3/19/10 By: Ralph L. [Signature]

State of California)

County of Los Angeles)

On 3-19-10 before me, Tunisia Johnson, a Notary Public, personally appeared Ralph Franklin who proved to me on the basis of satisfactory evidence to be the person(s) whose name(s) ~~is/are~~ subscribed to the within instrument and acknowledged to me that ~~he/she/they~~ executed the same in ~~his/her/their~~ authorized capacity(ies), and that by ~~his/her/their~~ signature(s) on the instrument the person(s), or the entity upon behalf of which the person(s) acted, executed the instrument.

I certify under PENALTY OF PERJURY under the laws of the State of California that the foregoing paragraph is true and correct.

WITNESS my hand and official seal.

Signature Tunisia Johnson

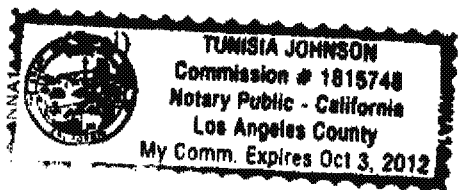

30

SUBORDINATION OF DEED OF TRUST

The property described in Exhibit "B" to the GRANT DEED AND IRREVOCABLE OFFER OF DEDICATION is encumbered by, among other things, a certain Deed of Trust, Security Agreement, Fixture Filing, and Assignment of Leases and Rents given as of September 25, 2005 and recorded September 26, 2005, in the Official Records of the Recorder's Office of Los Angeles County, California, as Instrument No. 05-2311588, by Hollywood Park Land Company, LLC, a Delaware limited liability company, Hollywood Park Fall Racing Association, LLC, a Delaware limited liability company, and Hollywood Park Racing Association, LLC, a Delaware limited liability company, to First American Title Insurance Company, as Trustee, for the use and benefit of SunAmerica Life Insurance Company (the "Beneficiary"); as amended by a certain First Amendment to Deed of Trust, Security Agreement, Fixture Filing, and Assignment of Leases and Rents and Other Loan Documents made as of July 7, 2006, and recorded July 10, 2006, in the Official Records of the Recorder's Office of Los Angeles County, California as Instrument No. 06-2806143; and as further modified by a certain Modification of Deed of Trust and Other Loan Documents dated as of August 14, 2009, and recorded August 17, 2009, in the Official Records of the Recorder's Office of Los Angeles County, California as Instrument No. 2009-1260901 (as the same may hereafter be amended, modified, extended or recast, the "Mortgage").

Beneficiary hereby acknowledges and agrees that the Mortgage on the property described in Exhibit "B" is and shall be subject and subordinate to the terms of the IRREVOCABLE OFFER OF DEDICATION of the Prairie Avenue ROW in the GRANT DEED AND IRREVOCABLE OFFER OF DEDICATION, and upon acceptance by the City of Inglewood, such easement shall be free and clear of the Mortgage.

Date: Dec. 7, 2009

BENEFICIARY

SUNAMERICA LIFE INSURANCE COMPANY, an Arizona corporation

By: AIG Global Investment Corp., a New Jersey corporation, its investment advisor

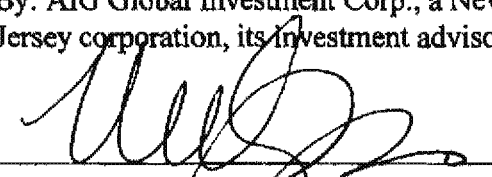
By: 

Name: Mada Campagna
Title: Vice President

ACKNOWLEDGMENT

State of California)

County of LOS ANGELES)

On DEC. 7, 2009 before me, JEFFREY GREATHOUSE, a Notary Public, personally appeared MARLA S. CAMPAGNA, who proved to me on the basis of satisfactory evidence to be the person(s) whose name(s) is/are subscribed to the within instrument and acknowledged to me that he/she/they executed the same in his/her/their authorized capacity(ies), and that by his/her/their signature(s) on the instrument the person(s), or the entity upon behalf of which the person(s) acted, executed the instrument.

I certify under PENALTY OF PERJURY under the laws of the State of California that the foregoing paragraph is true and correct.

WITNESS my hand and official seal.

Signature  (Seal)

