



GAVIN NEWSOM
GOVERNOR



JAHED BLUMENFELD
SECRETARY FOR
ENVIRONMENTAL PROTECTION

State Water Resources Control Board
Division of Drinking Water

June 11, 2019

Mr. Louis A. Atwell, P.E.
Public Works Director
Public Works Department
City of Inglewood
One Manchester Boulevard
P.O. Box 6500, 3rd Floor
Inglewood, CA 90301-1750

Dear Mr. Atwell:

SYSTEM NO. 1910051 – WATER SUPPLY PERMIT AMENDMENT 1910051PA-002

Please find enclosed the domestic water supply permit amendment (No. 1910051PA-002), dated June 11, 2019, and accompanying engineering report issued to the City of Inglewood to operate a new well, Well 7 and treat it at the Sanford M. Anderson Water Treatment Plant.

A public water system may file with the State Water Resources Control Board (State Water Board) a petition for reconsideration of a decision by the Deputy Director to issue, deny or amend a permit. Petitions must be received by the State Water Board within 30 calendar days of the issuance of the permit, permit amendment or decision. The date of issuance is the date when the Division of Drinking Water mails or serves a copy of the permit, permit amendment, or decision, whichever occurs first. If the 30th day falls on a Saturday, Sunday, or state holiday, the petition is due the following business day. Petitions must be received by 5:00 p.m. Information regarding filing petitions may be found at: http://www.waterboards.ca.gov/drinking_water/programs/petitions/index.shtml

Please acknowledge receipt of this permit amendment and your willingness to comply with the permit conditions in writing within 30 days. If you have any questions, please contact Karen Wong at (818) 551-2037.

E. JOAQUIN ESQUIVEL, CHAIR | EILEEN SOBECK, EXECUTIVE DIRECTOR

500 North Central Avenue, Suite 500, Glendale, CA 91203 | www.waterboards.ca.gov

Sincerely,

A handwritten signature in black ink, appearing to read 'Chi Diep', written in a cursive style.

Chi Diep, P.E.
District Engineer
Metropolitan District

Cc: Thomas Lee, P.E.
Associate Engineer
City of Inglewood

PERMIT AMENDMENT NO. 1910051PA-002

City of Inglewood

**Los Angeles County
System No. 1910051**

June 11, 2019



CALIFORNIA

Water Boards

**STATE WATER RESOURCES CONTROL BOARD
DIVISION OF DRINKING WATER**

STATE OF CALIFORNIA

AMENDMENT TO THE

DOMESTIC WATER SUPPLY PERMIT ISSUED TO

City of Inglewood
Public Water System - 1910051

ORIGINAL PERMIT: *Not Numbered*

DATE OF ISSUE: **06/18/65**

REVISED: **12/27/00**

PERMIT AMENDMENT: *Not Numbered*

EFFECTIVE DATE: **10/07/83**

PERMIT AMENDMENT: *Not Numbered*

EFFECTIVE DATE: **10/22/90**

PERMIT AMENDMENT: **1910051PA-001**

EFFECTIVE DATE: **04/12/04**

PERMIT AMENDMENT: *Not Numbered*

EFFECTIVE DATE: **01/17/17**

PERMIT AMENDMENT: **1910051PA-002**

EFFECTIVE DATE: **06/11/19**

WHEREAS:

- I. The *City of Inglewood (hereinafter, the City)* submitted an application to the State Water Resources Control Board, Division of Drinking Water (hereinafter, the Division) on **August 28, 2018** for an amendment to the Domestic Water Supply Permit issued to *the City* on **June 18, 1965, revised December 27, 2000**.
- II. The purpose of the amendment, as stated in the application, is to allow *the City* to make the following modifications to the public water system:

To operate a new well, Well 7, and treat it at the City's Sanford M. Anderson Water Treatment Plant for iron and manganese removal.
- III. *The City* has submitted all of the supporting information required to evaluate the application.
- IV. The Division has evaluated the application and the supporting material and has determined that the proposed modifications comply with all applicable State drinking water requirements.

THEREFORE:

- I. The Division hereby approves the application submitted by *the City* for a permit amendment. The Domestic Water Supply Permit issued to *the City* on **December 27, 2000** is hereby amended as follows:

The City may operate Well 7 and treat it at the Sanford M. Anderson Water Treatment Plant.

- II. This permit amendment is subject to the following conditions:

GENERAL

1. The City shall comply with all the requirements set forth in the California Safe Drinking Water Act, California Health and Safety Code and any regulations, standards, or orders adopted hereunder.
2. All water supplied by the City for domestic purposes shall meet all Maximum Contaminant Levels (MCLs) established by the State Water Resources Control Board, Division of Drinking Water. If the water quality does not comply with the California Drinking Water Standards, additional treatment shall be provided to bring the water into compliance with standards.
3. The only approved sources of domestic water supply are listed in Tables 1 and 2.

Table 1. Approved Groundwater Sources

Source	PS Code	Status	Capacity (gpm)
Well 1	1910051-001	Active	600
Well 2	1910051-002	Active	600
Well 4	1910051-013	Active	800
Well 6	1910051-018	Active	1400
Well 7	1910051-019	Active	1500

Table 2. Other Sources

Sources	PS Code	Status	Capacity (gpm)
MWD WB 17	1910051-017	Active	6600
MWD WB 38	1910051-016	Active	4400

4. The only approved treatment facilities are listed in Table 3.

Table 3. Approved Treatment Facilities

Facility	Treatment	PS Code	Treatment Plant Classification
Sanford M. Anderson Water Treatment Plant	For manganese and iron removal: <ul style="list-style-type: none"> • Oxidation with KMnO4 • Prechlorination to breakpoint, • Filtration • Postchloramination 	1910051-015 (Influent)	T2
		1910051-014 (Effluent)	
North Inglewood Reservoir	Sodium hypochlorite chlorination - to be used for emergencies only		T1
Morningside Reservoir	Sodium hypochlorite chlorination - to be used for emergencies only		T1

5. No other sources and/or treatment facilities other than those outlined in Provisions 3 and 4 shall be added or used without prior approval from the Division through an amended permit.
6. Only personnel who have been certified in accordance with the Operator Certification Regulations, Chapter 13, Title 22, California Code of Regulations (CCR) shall operate the distribution system. The City's distribution system has been classified as a D5 system. Therefore, the designated Chief and Shift distribution operators shall possess minimum grade D5 and D3 certificates, respectively.
7. All treatment facilities shall be operated by personnel who have been certified in accordance with the Operator Certification Regulations, Chapter 13, Title 22 of CCR. The classifications for all applicable treatment facilities are listed in Table 3. The Sanford M. Anderson Water Treatment Plant has been classified as a T2

treatment facility, which requires minimum grade T2 and T1 certificates for the chief and shift treatment operators, respectively. For the facilities that consist of only disinfection stations, the City may utilize either certified distribution operators or treatment operators that have been trained to operate these facilities.

8. All groundwater wells listed in Provision 3 shall be monitored in accordance with the regulations contained in Title 22, CCR, and the most recent Vulnerability Assessment and Monitoring Frequency Guidelines issued by the Division. All results shall be submitted to the Division electronically using the designated PS codes.
9. The City shall collect raw water samples prior to disinfection from each active well monthly for total coliform analysis using EPA standard methods unless a higher monitoring frequency is required. If a positive total coliform sample is detected, the sample shall also be analyzed for fecal coliform, or *E. Coli* bacteria. Results shall be submitted to the Division in a summary form by the 10th day of the month, following the month in which the samples were collected.
10. The City shall comply with Title 17, CCR, to prevent the water system and treatment facilities from being contaminated by possible cross-connections. The City shall maintain a program for the protection of the domestic water system against backflow from premises having dual or unsafe water systems in accordance with Title 17. All backflow prevention devices shall be tested annually.
11. Pursuant to Sections 64590 and 64591, Title 22, CCR, no chemical or product shall be added to drinking water as a part of the treatment process unless it has been certified as meeting the specifications of American National Standard Institute/National Sanitation Foundation (ANSI/NSF) Standard 60, and no indirect additive shall be used unless it has been certified as meeting the specifications of ANSI/NSF Standard 61. The City may use an uncertified chemical, material, or product if the requirements specified in Section 64593 are met, or if an alternative is proposed that meets the requirements in Section 64551.100.

SANFORD M. ANDERSON WATER TREATMENT PLANT

12. The City shall operate the Sanford M. Anderson Water Treatment Plant in accordance with its approved Operations and Maintenance Plan with the following operational requirements:
 - a. The Sanford Treatment Plant shall not be operated above its maximum capacity of 8.64 MGD.
 - b. Wells 1, 2, 4, 6, and 7 shall be treated at the Sanford Treatment Plant at all times for iron and manganese removal.

- c. The treated effluent shall comply with the iron and manganese secondary MCLs of 0.3 mg/L and 0.05 mg/L, respectively.
 - d. The treated effluent shall be continuously and reliably disinfected to achieve a minimum total chlorine residual of 1.0 mg/L at the entry point of the distribution system.
 - e. The Operations and Maintenance Plan should be periodically reviewed and updated as necessary. Any revised plan shall be submitted to the Division for review and approval.
13. Compliance with the iron and manganese secondary MCLs shall be based on a monthly average of weekly samples collected at the Sanford Treatment Plant effluent (PS code 1910051-014).
 14. A monthly compliance report for the Sanford Treatment Plant shall be submitted to the Division by the 10th of the following month. Monitoring for iron, manganese, color, odor, turbidity shall be conducted monthly at Wells 1, 2, 4, 6, and 7 and plant influent (PS code 1910051-015) and weekly at the plant effluent (PS code 1910051-014). All monitoring analyses shall be performed by a State certified laboratory and results transmitted by electronic data transfer (EDT) to the Division.
 15. The City shall submit an annual report for the water quality data collected from the WRD monitoring wells located in the vicinity of Well 7.
 16. All instruments, including but not limited to, chemical analyzers and flow meters, shall be calibrated at the frequencies and by the methods recommended by their respective manufacturers. Records for all instrument calibrations shall be maintained by the City, and made available to the Division when requested.
 17. The City shall maintain an Operator's Log Book to record all activities, events, and problems with the operations of the wells and Sanford Treatment Plant.

This amendment shall be appended to and shall be considered to be an integral part of the Domestic Water Supply Permit issued to the *City of Inglewood* on *June 18, 1965*, revised *December 27, 2000*.

FOR THE STATE WATER RESOURCES CONTROL BOARD

June 11, 2019
Date



Chi Diep, P.E., District Engineer
Metropolitan District, Los Angeles Region

Engineering Report

*For the Consideration of the Amended Permit for
The City of Inglewood
Serving the City of Inglewood
Los Angeles County*

June 11, 2019

*Southern California Branch
Division of Drinking Water
State Water Resources Control Board*

Prepared By

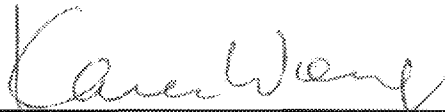

*Karen Wong, P.E.
Associate Sanitary Engineer
Metropolitan District*

Reviewed and Approved By

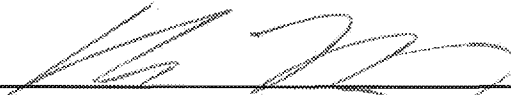

*Chi Diep, P.E.
District Engineer
Metropolitan District*

I. PURPOSE OF REPORT

The City of Inglewood (hereinafter, the City) has submitted an application, dated August 28, 2018, for an amended permit to operate a new well, Well 7. A copy of the permit application is provided in Appendix 1. The purpose of this report is to evaluate the City's proposal, document the sanitary engineering review, and make recommendations regarding the issuance of an amended domestic water supply permit.

II. BRIEF DESCRIPTION OF THE SYSTEM

The City of Inglewood is located in the middle of Los Angeles County and is bounded on the south by the City of Hawthorne and by the City of Los Angeles and Los Angeles County on the other boundaries. The City encompasses approximately 9.2 square miles. The City is comprised of commercial, industrial, and residential zoning. The City currently serves an estimated population of 86,420 through 15,840 active metered service connections. The service area map and hydraulic schematic are provided in Appendix 2 of this report.

The City's source of water supply consists of local groundwater supply in the West Coast Groundwater Basin and imported water from Metropolitan Water District of Southern California (MWD) through its MWD member agency, West Basin Municipal Water District (WBMWD). The City's system consists of five wells (including the City's new well, Well 7), two connections with MWD (WB-17 and WB-38), eight emergency connections (six with Golden State Water Company and two with Los Angeles Department of Water and Power), two reservoirs, three pressure zones, and pump stations (North Inglewood Pump Station and Morningside Pump Station). Groundwater from the City wells is treated for iron and manganese at the City's Sanford M. Anderson Water Treatment Plant (Sanford Treatment Plant) to meet the Secondary MCLs for these two inorganic constituents.

The City is currently operating under a domestic water supply permit issued by the Department of Public Health (Drinking Water Program under the State Water Resources Control Board, Division of Drinking Water) on June 18, 1965 (revised December 27, 2000 and January 11, 2001). The permit and amendment issued to the City are summarized in Table 2-1 below.

Table 2-1. Permit History

Issue Date	Permit No.	Description
06/18/1965	Not Numbered	Full Permit
10/07/1983	Not Numbered	To include the Sanford M. Anderson Treatment Plant to treat groundwater pumped from Wells 1, 2, and 3
10/22/1990	Not Numbered	To operate Well 4, which was to replace Well 3.
12/27/2000 (rev'd 1/11/2001)	04-15-00P-023	Revised Full Permit

Issue Date	Permit No.	Description
04/12/2004	1910051PA-001	To operate Well 6
01/17/2017	Not Numbered	To include requirements for lead sampling at K-12 schools
New	1910051PA-002	To operate Well 7

Sources of Information

Information used to prepare this report was obtained from the State Water Resources Control Board, Division of Drinking Water (hereinafter, the Division) files, City personnel, a review of the City's files and records, and a visit to the new facility conducted on May 8, 2019. The investigation, analyses and preparation of this report were conducted by Karen Wong, P.E., Associate Sanitary Engineer with the Division, Metropolitan District, under the supervision of Chi Diep, P.E., Metropolitan District Engineer.

III. INVESTIGATION FINDINGS

A. Description of Well 7

Well 7 is located on a parking lot owned by the City at the northwest corner of Arbor Vitae Street and Grevillea Avenue in the City of Inglewood. Like other City's wells, Well 7 produces groundwater that will require treatment for total dissolved solids, iron, and manganese. Therefore the groundwater from Well 7 along with the other City's wells will be treated for iron and manganese at the City's Sanford Treatment Plant.

The well was drilled in 2018, using the reverse circulation method. The bore hole was drilled to a depth of 716 feet. A 20-inch diameter high strength, low alloy steel casing was installed from 0 to 620 below ground surface (bgs). A 42-inch diameter low carbon steel conductor casing was installed from ground surface to a depth of 50 feet. The well has a 310-foot deep annular seal filled with cement. It is also gravel packed and surface sealed.

The well is screened from 352-410 and 532-581 feet bgs, using a 20-inch diameter high strength low alloy steel well casing with 0.070-inch slot opening. The total length of the screened intervals is 197 feet. The distances to the highest perforation, the static water level and pumping water level are 352, 112, and 208 feet bgs, respectively.

The well has an estimated maximum yield capacity of 1,500 gpm, based on a pump test conducted in May 2018. The well is equipped with a submersible pump, which has a 200-horsepower electric motor with a pumping capacity of 1,500 gpm. The well is also equipped with the appropriate appurtenances such as an inverted and screened air relief valve, casing vent, flow meter, sounding tube, and sampling tap. The well site is fenced and locked to prevent unauthorized access.

The closest sewer line is located approximately 70 feet away from the well. More details on the well are provided on the well diagram and well data sheet in Appendix 3. Per Title 22, Section 64560, the City has provided pump test results, well construction permit issued by the Los Angeles County Health Department, and well completion report. A copy of the pump test results is provided in Appendix 3. Since the well completion report and well construction permit contain confidential information, they will not be attached to this report but will be kept on file with the Division.

One complete set of Title 22 sampling was collected from Well 7 including general mineral, general physical, inorganic, and organic compounds in May 2018 and May 2019. The results indicate that Well 7 water is in compliance with all primary and secondary MCLs except for iron and manganese, which will be treated at the City's Sanford M. Anderson Water Treatment Plant. A copy of the results including general mineral, general physical, inorganic, and organic compounds is attached in Appendix 3.

Bacteriological samples and heterotrophic plate count (HPCs) were also collected on May 2, 2019. The results indicate that the well is absent for coliforms with the HPCs below 500 cfu/ml, as shown in Appendix 3.

Well 7 shall be monitored in accordance with the most recent Vulnerability Assessment and Monitoring Frequency Guidelines (VA Guidelines) for source class code LGLE, which is the code assigned to all of the City's wells. A copy of the VA Guidelines is provided in Appendix 4.

In addition, because Well 7 is a new groundwater well, the City shall complete the following initial monitoring requirements including four (4) consecutive quarters of VOCs, four (4) consecutive quarters of radionuclides, four (4) consecutive quarters of 1,2,3-Trichloropropane (1,2,3-TCP), two (2) samples, five to seven months apart, for perchlorate, and one quarter of all SOC's followed by three consecutive quarters of SOC's that are not waived. More details are provided below.

VOC Monitoring

The City has completed the first quarterly VOCs samples on May 2, 2019 and all results were non-detect. To complete the initial VOCs monitoring requirements, the City shall collect three (3) more consecutive quarterly VOCs samples starting in August 2019.

Radiological Monitoring

In accordance with Title 22, Section 64442 (c), the City shall begin initial radiological monitoring for Well 7, within the first quarter after initiating water service to the public. To date, the City has performed one quarter of monitoring for gross alpha (GA), uranium, radium 226, and radium 228 at Well 7 in May 2019. The City shall complete the initial radiological monitoring requirements by collecting three (3) more consecutive quarterly samples for the analyses of GA, uranium, radium 226, and radium 228.

Subsequent monitoring requirements for these constituents will be determined based on the results of the data collected from this initial monitoring period.

Perchlorate Monitoring

The California perchlorate MCL of 0.006 mg/L became effective on October 18, 2007. To comply with the initial perchlorate monitoring requirement of this regulation for Well 7, the City shall collect two (2) samples, five to seven months apart, with at least one gathered between May 1 and September 30. The first sample was collected on May 2, 2019 and the result was non-detect. The second sample shall be collected between October and December 2019.

SOC Monitoring

The City has completed a quarter of all SOCs samples on May 2, 2019 and all results were non-detect. To complete the initial SOC monitoring requirements, the City shall collect three (3) more consecutive quarterly SOCs samples that were not waived as indicated in the attached VA Guidelines for source class code LGLE starting in August 2019.

Groundwater Rule

In compliance with the Groundwater Rule per CCR, Title 22, Section 141.400, the City is required to perform compliance monitoring to demonstrate 4-log treatment of viruses in lieu of performing the triggered source water monitoring. This requirement will remain unchanged with the addition of Well 7. The City is required to maintain the minimum daily chlorine residual of at least 0.2 mg/L required to achieve the calculated CT value of 3.6 mg-min/L for 4-log treatment of virus at the two (2) 202,500-gallon contact tanks. Monthly reports of the minimum daily disinfectant residual recorded for each day of the month are submitted to the Division on the 10th of the following month.

1,2,3-TCP Monitoring

The State adopted a MCL of 5 ppt for 1,2,3-TCP on December 14, 2017. To comply with the initial 1,2,3-TCP monitoring requirement of this regulation for Well 7, the City shall conduct one year of sampling consisting of four (4) consecutive quarters of sampling. The first quarterly sample was collected on May 2, 2019 and the result was non-detect. The City shall collect three (3) more quarterly samples starting in August 2019 and submit all results to the Division by electronic data transfer (EDT).

Drinking Water Source Assessment and Protection (DWSAP) Program

The Drinking Water Source Assessment for Well 7 was conducted by the City of Inglewood Water Division and Richard C. Slate Associates, LLC, Consulting Groundwater Geologists. A copy is kept on file with the Division. The well is considered to have 'high' physical barrier effectiveness (PBE). The well is considered

most vulnerable to 1) dry cleaners, 2) car washers, 3) automobile repair shops, 4) bus terminals, and 5) other building structures in the area.

B. Sanford M. Anderson Water Treatment Plant

In 1975, the Sanford M. Anderson Water Treatment Plant was constructed to treat groundwater pumped from Wells 1, 2, and 3 for high iron and manganese content. Well 3 was later replaced by Well 4 in 1990 while Well 6 was added in 2004. With the addition of the new well, Well 7, the Sanford Treatment Plant with a design capacity of 8.64 MGD or 6,000 gpm will treat all of the City's wells (Wells 1, 2, 4, 6, and 7) to bring iron and manganese levels to compliance with their respective secondary MCLs of 0.3 mg/L and 0.05 mg/L.

The Sanford Treatment Plant consists of potassium permanganate oxidation and pre-chlorination, gravity filtration through dual-media filters consisting of manganese greensand and anthracite coal, and post-chloramination. The treated water will be stored in an underground 834,000-gallon clearwell prior to being pumped to North Inglewood Reservoir and Morningside Reservoir. On the Morningside direction, however, since Morningside Reservoir has been out of service since 2009 due to structural problems, the treated water would get mixed directly with purchased MWD water from WB-17 at the mixing chamber. From there, the treated water is distributed to serve Inglewood Pressure Zone 3. Currently there is no transmission line directly connected to Morningside Reservoir because there is no plan in place to repair or rehabilitate the reservoir. However, the City may consider demolishing the Morningside Reservoir and building a new reservoir of smaller scale at the same location. A schematic of the Sanford Treatment Plant and treatment plant data sheet are provided in Appendix 2.

Potassium Permanganate Oxidation and Pre-Chlorination

Water from the five wells enters the plant through a 27-inch transmission main before being equally distributed into two (2) 202,500-gallon contact tanks. Prior to entering the contact tanks, potassium permanganate (KMnO_4), used as an oxidant and for the regeneration of greensand, is injected into the plant influent line at two (2) percent strength. The permanganate dosage will be adjusted periodically according to iron and manganese concentrations in the influent and based upon jar testing results. The chlorine injection point is located immediately downstream, approximately 20 feet, of the KMnO_4 injection point. Chlorine is injected as another oxidant to achieve breakpoint chlorination.

Filtration

Six (6) dual-media filters, each with a surface area of 242 ft² (11 feet by 22 feet), are provided for the filtration process. The filtration rate at the maximum design capacity is 4 gpm/ft² with all the filters in service, and 5.0 gpm/ft² with one filter out of service for backwash. The filter media consist of 18 inches of anthracite coal on top of 18 inches of manganese greensand, with a support medium of 15 inches of graded gravel. The

filters are gravity fed at a constant rate with equal flow distribution to each filter through circular adjustable weirs installed on the filter inlet pipes. The filter backwash (surface wash will also be included whenever the backwash is activated) can be controlled either automatically based on high turbidity (0.5 NTU), high head loss (10 feet), elapsed time since last completed backwash (120 hours) or manually through a computer command by the operator.

Post-Chloramination Facilities

A 1,500-gallon aqua ammonia storage tank, and three (3) feed pumps are utilized at the Sanford Treatment Plant. These pumps are rated at 1 to 20.6 gallons per day. The 21.17⁰ BE aqua ammonia at 19 percent strength is injected in the compartment downstream of the treated (filtered) water level control weirs. The current ammonia-nitrogen dosage rate is about 0.7 mg/L, which is about a 5 to 1 ratio of chlorine to ammonia-nitrogen.

Clearwell, Plant Effluent Pumping Station, and other Facilities

After chloramination, the filtered water flows through an existing transfer pump station (which connects to six (6) vessels of sodium zeolite softener that are no longer being use) and enters the plant clearwell. The clearwell, which has a storage capacity of 834,000 gallons, is located beneath the administration and chemical building at the plant. The total chlorine residual in the water is continuously monitored by a Wallace and Tiernan automatic residual analyzer-SCADA monitored at two (2) locations, the inlet to the clearwell and the plant's outlet. The water level in the clearwell is also closely monitored because the water for backwashing the filters is drawn from the clearwell. The backwash pump operation will be terminated if the clearwell water level is below the low-level set point. Upon exiting the plant clearwell, the treated water is pumped to the Morningside and North Inglewood pressure regulating stations. From there the water is introduced into the distribution system.

Monitoring

The City collects samples for iron, manganese, color, odor, turbidity monthly at the wells and plant influent and weekly at the plant effluent (clearwell). All results are submitted to the Division in a monthly report and by EDT on the 10th of the following month.

C. Treatment Classification

Although Well 7 will bring in an additional capacity of 1,500 gpm to the Sanford Treatment Plant, the Sanford Treatment Plant with a design capacity of 8.64 MGD will still have adequate capacity to treat all of the City's five wells (Wells 1, 2, 4, 6, and 7). Over the years, Wells 1, 2, 4, and 6 have experienced at least a 50% drop in capacity, bringing the combined well capacity (including Well 7) to 7.06 MGD. The Sanford Treatment Plant will continue to be classified as a T2 treatment facility in accordance with the Operator Certification Regulations of the California Code of Regulations, Title 22. A breakdown of the points assigned to the Sanford Treatment Plant in determining

the treatment facility classification is included in Appendix 5. Operator certification requirements for a T2 facility include a chief operator with a minimum T2 grade and shift operators with a minimum T1 grade.

D. California Environmental Quality Act (CEQA)

The State Water Resources Control Board, Division of Drinking Water (Division), as a responsible agency pursuant to CEQA, has reviewed the Mitigated Negative Declaration (MND) prepared by the City, dated September 19, 2014. On October 23, 2014, a Notice of Intent (NOI) was filed with the Los Angeles County Clerk and posted from October 23, 2014 to November 24, 2014 announcing the public hearing and plan to adopt the Draft MND. On November 18, 2014, the Draft MND was adopted by Resolution No. 15-12, including implementation of the proposed mitigation measures. The City developed a Final MND dated November 30, 2014. On December 17, 2014, the City filed a Notice of Determination with the Los Angeles County Clerk.

More than one year after the City adopted the MND, the document was distributed to the public and circulated with the State Clearinghouse (SCH # 2016021083) for a 30-day review period beginning on February 22, 2016 and ending on March 22, 2016. During the public review period, one written comment was received from the Department of Transportation. The City filed the MND a second time with the SCH for a 45-day review period beginning on September 21, 2016 and ending on November 4, 2016, and it was sent to the Office of Historic Preservation and the Native American Heritage Commission as reviewing agencies. The Office of Planning Research sent a letter confirming that no state agencies submitted comments during this comment period.

As a responsible agency, the Division has considered the Project MND dated November 30, 2014 together with all comments and Division of Financial Assistance, Special Project Review Unit staff hereby recommend the following findings for the Project:

The project will not result in any significant water quality impacts. There are no recommended permit conditions.

CEQA documents are provided in Appendix 1 of this report.

IV. ENGINEERING APPRAISAL OF SANITARY HAZARDS AND SAFEGUARDS

A review of the plans indicates that the design and construction of the new well, Well 7, is in accordance with AWWA standards and the California Waterworks Standards and is free from sanitary hazards. It is anticipated that Well 7 will be treated successfully together with the other City's wells at the Sanford M. Anderson Water Treatment Plant for iron and manganese.

In late 2015, Regional Water Quality Control Board (RWQCB) expressed concern that the pumping of Well 7 might impact contaminant plume and/or contaminated

groundwater currently existing beneath the known hazardous waste sites in the local area. Consequently, the City hired Richard C. Slade & Associates (RCS) to review available data on the hazardous waste sites of concern and to provide an evaluation of potential hydrogeologic impact, if any, of Well 7 on the contaminated groundwater beneath those sites. A report titled "Review of Nearby Hazardous Waste Sites & Capture Zone Analysis for Proposed City Well No. 7" was prepared by RCS on February 18, 2016. The report concluded that the groundwater that is to be extracted from the Lynwood and/or Silverado aquifers by Well 7 does not appear to have been affected by groundwater contamination from the nearby hazardous waste sites. Also the results of the capture zone analysis revealed that each of the nearby RWQCB-defined hazardous sites was found to be outside the 10-year capture zone (or source water) for each of the two pumping scenarios listed in the report. Thus it does not appear that the future pumping of Well 7 will likely impact the groundwater contamination plumes that may exist beneath the known RWQCB-defined hazardous waste sites.

The City is required to keep monitoring water quality data from Water Replenishment District (WRD) monitoring wells at regular intervals in addition to monitoring water quality data produced from Well 7. If the water quality data shows MCL exceedance in Well 7, treatment will be required at this well before the water may be served to the customers.

V. CONCLUSIONS AND RECOMMENDATIONS

The State Water Resources Control Board, Division of Drinking Water (Division), finds that the Sanford M. Anderson Water Treatment Plant is capable of treating the City's existing groundwater wells and the new well, Well 7, to provide safe, wholesome and potable water that meets all applicable State Drinking Water Standards. Issuance of an amended domestic water supply permit by the State Water Resources Control Board, Division of Drinking Water, to the City for the operation of Well 7 and the existing Sanford M. Anderson Water Treatment Plant is recommended subject to the following provisions:

GENERAL

1. The City shall comply with all the requirements set forth in the California Safe Drinking Water Act, California Health and Safety Code and any regulations, standards, or orders adopted hereunder.
2. All water supplied by the City for domestic purposes shall meet all Maximum Contaminant Levels (MCLs) established by the State Water Resources Control Board, Division of Drinking Water. If the water quality does not comply with the California Drinking Water Standards, additional treatment shall be provided to bring the water into compliance with standards.

3. The only approved sources of domestic water supply are listed in Tables 1 and 2.

Table 1. Approved Groundwater Sources

Source	PS Code	Status	Capacity (gpm)
Well 1	1910051-001	Active	600
Well 2	1910051-002	Active	600
Well 4	1910051-013	Active	800
Well 6	1910051-018	Active	1400
Well 7	1910051-019	Active	1500

Table 2. Other Sources

Sources	PS Code	Status	Capacity (gpm)
MWD WB 17	1910051-017	Active	6600
MWD WB 38	1910051-016	Active	4400

4. The only approved treatment facilities are listed in Table 3.

Table 3. Approved Treatment Facilities

Facility	Treatment	PS Code	Treatment Plant Classification
Sanford M. Anderson Water Treatment Plant	For manganese and iron removal: <ul style="list-style-type: none"> • Oxidation with KMnO4 • Prechlorination to breakpoint, • Filtration • Postchloramination 	1910051-015 (Influent)	T2
		1910051-014 (Effluent)	
North Inglewood Reservoir	Sodium hypochlorite chlorination - to be used for emergencies only		T1
Morningside Reservoir	Sodium hypochlorite chlorination - to be used for emergencies only		T1

5. No other sources and/or treatment facilities other than those outlined in Provisions 3 and 4 shall be added or used without prior approval from the Division through an amended permit.
6. Only personnel who have been certified in accordance with the Operator Certification Regulations, Chapter 13, Title 22, California Code of Regulations (CCR) shall operate the distribution system. The City's distribution system has been classified as a D5 system. Therefore, the designated Chief and Shift distribution operators shall possess minimum grade D5 and D3 certificates, respectively.
7. All treatment facilities shall be operated by personnel who have been certified in accordance with the Operator Certification Regulations, Chapter 13, Title 22 of CCR. The classifications for all applicable treatment facilities are listed in Table 3. The Sanford M. Anderson Water Treatment Plant has been classified as a T2 treatment facility, which requires minimum grade T2 and T1 certificates for the chief and shift treatment operators, respectively. For the facilities that consist of only disinfection stations, the City may utilize either certified distribution operators or treatment operators that have been trained to operate these facilities.
8. All groundwater wells listed in Provision 3 shall be monitored in accordance with the regulations contained in Title 22, CCR, and the most recent Vulnerability Assessment and Monitoring Frequency Guidelines issued by the Division. All results shall be submitted to the Division electronically using the designated PS codes.
9. The City shall collect raw water samples prior to disinfection from each active well monthly for total coliform analysis using EPA standard methods unless a higher monitoring frequency is required. If a positive total coliform sample is detected, the sample shall also be analyzed for fecal coliform, or *E. Coli* bacteria. Results shall be submitted to the Division in a summary form by the 10th day of the month, following the month in which the samples were collected.
10. The City shall comply with Title 17, CCR, to prevent the water system and treatment facilities from being contaminated by possible cross-connections. The City shall maintain a program for the protection of the domestic water system against backflow from premises having dual or unsafe water systems in accordance with Title 17. All backflow prevention devices shall be tested annually.
11. Pursuant to Sections 64590 and 64591, Title 22, CCR, no chemical or product shall be added to drinking water as a part of the treatment process unless it has been certified as meeting the specifications of American National Standard Institute/National Sanitation Foundation (ANSI/NSF) Standard 60, and no indirect additive shall be used unless it has been certified as meeting the specifications of ANSI/NSF Standard 61. The City may use an uncertified chemical, material, or

product if the requirements specified in Section 64593 are met, or if an alternative is proposed that meets the requirements in Section 64551.100.

SANFORD M. ANDERSON WATER TREATMENT PLANT

12. The City shall operate the Sanford M. Anderson Water Treatment Plant in accordance with its approved Operations and Maintenance Plan with the following operational requirements:
 - a. The Sanford Treatment Plant shall not be operated above its maximum capacity of 8.64 MGD.
 - b. Wells 1, 2, 4, 6, and 7 shall be treated at the Sanford Treatment Plant at all times for iron and manganese removal.
 - c. The treated effluent shall comply with the iron and manganese secondary MCLs of 0.3 mg/L and 0.05 mg/L, respectively.
 - d. The treated effluent shall be continuously and reliably disinfected to achieve a minimum total chlorine residual of 1.0 mg/L at the entry point of the distribution system.
 - e. The Operations and Maintenance Plan should be periodically reviewed and updated as necessary. Any revised plan shall be submitted to the Division for review and approval.
13. Compliance with the iron and manganese secondary MCLs shall be based on a monthly average of weekly samples collected at the Sanford Treatment Plant effluent (PS code 1910051-014).
14. A monthly compliance report for the Sanford Treatment Plant shall be submitted to the Division by the 10th of the following month. Monitoring for iron, manganese, color, odor, turbidity shall be conducted monthly at Wells 1, 2, 4, 6, and 7 and plant influent (PS code 1910051-015) and weekly at the plant effluent (PS code 1910051-014). All monitoring analyses shall be performed by a State certified laboratory and results transmitted by electronic data transfer (EDT) to the Division.
15. The City shall submit an annual report for the water quality data collected from the WRD monitoring wells located in the vicinity of Well 7.
16. All instruments, including but not limited to, chemical analyzers and flow meters, shall be calibrated at the frequencies and by the methods recommended by their respective manufacturers. Records for all instrument calibrations shall be maintained by the City, and made available to the Division when requested.

17. The City shall maintain an Operator's Log Book to record all activities, events, and problems with the operations of the wells and Sanford Treatment Plant.

APPENDICES

1. Permit Amendment Application and CEQA Documents
2. Service Area Map, Hydraulic Schematic, Sanford Treatment Plant Schematic, Treatment Plant Data Sheet
3. Well Diagram, Well Data Sheet, Pump Test Results, Title 22 Test Results, and Bacteriological Test Results
4. Vulnerability Assessment and Monitoring Frequency Guidelines LGLE
5. Treatment Facility Classification Worksheet

APPENDIX 1

Permit Amendment Application
CEQA Documents

STATE OF CALIFORNIA
APPLICATION
FOR
DOMESTIC WATER SUPPLY PERMIT AMENDMENT
FROM

Applicant: City of Inglewood
(Enter the name of legal owner, person(s) or organization)

Address: 1 West Manchester Blvd., Inglewood, CA 90301

System Name: City of Inglewood

System Number: 1910051



TO: Chi P. Diep, District Engineer
District 15 - Metropolitan
State Water Resources Control Board
Division of Drinking Water
500 North Central Avenue, Suite 500
Glendale, CA 91203

Pursuant and subject to the requirements of the California Health and Safety Code, Division 104, Part 12, Chapter 4 (California Safe Drinking Water Act), Article 7, Section 116550, relating to changes requiring an amended permit, application is hereby made to amend an existing water supply permit to construct a new well (Inglewood Well 7) for groundwater production.
(Applicant must state specifically what is being applied for - whether to construct new works, make alterations or additions in works or sources, or change or modify treatment.)

md

FOR OFFICIAL USE

Date Received:

I (We) declare under penalty of perjury that the statements on this application and on the accompanying attachments are correct to my (our) knowledge and that I (we) are acting under authority and direction of the responsible legal entity under whose name this application is made.

Signed By: [Signature]
Title: City of Inglewood Public Works Director
Address: 1 West Manchester Blvd., Inglewood, CA 90301
Telephone: (310) 412-5333

Dated: 2/22/18

NOTICE OF DETERMINATION

TO: Governor's Office of Planning and Research FROM: State Water Resources Control Board
State Clearinghouse Metropolitan District
Office P.O. Box 3044 500 North Central Avenue, Suite 500
Sacramento, CA 95812-3044 Glendale, CA 91203

SUBJECT: Filing of Notice of Determination in compliance with Section 21108 of the Public Resources Code

SCH#: 2016021083

WATER SYSTEM #: 1910051

PROJECT TITLE: Operation of City of Inglewood – New Well No. 7 Project (Project)

LEAD AGENCY: City of Inglewood (City)

CONTACT PERSON: Thomas Lee

PHONE NUMBER: (310) 412-5333

RESPONSIBLE AGENCY: State Water Resources Control Board (State Water Board)

CONTACT PERSON: Chi P. Diep

PHONE NUMBER: (818) 551-2004

PROJECT LOCATION: 101 West Arbor Vitae Street, Inglewood, CA 90301, Los Angeles County

PROJECT DESCRIPTION: The City proposed Project involved construction of a new water production well on a City owned parking lot in an urban area to include:

1. Demolish existing pavement and remove nine (9) existing trees on the site (*Remove 9-trees: 2@10"-diam, 1@12"-diam, 4@14"-diam, 1@16"-diam, 1@18"-diam*).
2. Construct 12-inch RCP wastewater storm drain (SD) line connecting to LA County 36-inch SD main (permit obtained).
3. Install a 24-foot sound-insulation wall for noise control around the site perimeter for the duration of the Project.
4. Provide for water treatment using two above-ground settling tanks for NPDES compliance during drilling.
5. Drill a 48-inch diameter hole and install a 42" conductor casing 50-feet below ground surface (bgs).
6. Drill a 17 ½-inch pilot bore-hole from 50-feet to 700-feet bgs.
7. Perform downhole geophysical surveying and then isolated aquafer zone testing.
8. Collect samples and send to laboratory for testing.
9. Ream pilot borehole to 38-inch from 50-feet to 350-feet bgs and then ream pilot borehole 30-in from 350-feet to 640-feet.
10. Provide caliper survey and then magnetic deviation survey.
11. Install new 20-inch High-Strength Low Alloy (HSLA) well casing (total 642 feet).
3-inch gravel feeding tube and 2-inch sounding tube.
12. Install Tacna Sand and Gravel pack.
13. Install annular cement/grout seal from 5-feet to 300-feet bgs.
14. Conduct alignment survey.
15. Mechanically develop the well.

PUBLIC AGENCY APPROVING PROJECT AND CARRYING OUT PROJECT: This is to advise that the State Water Board has issued a drinking water supply permit 1910051PA-002 for the above described Project on June 11, 2019, and has made the following determinations regarding the Project:

1. The Project will not have significant effects on water quality.
2. A Mitigated Negative Declaration (MND) was prepared for this Project pursuant to the provisions of the California Environmental Quality Act (CEQA).
3. Mitigation measures were not made conditions of the issuance of this permit.
4. A mitigation monitoring and reporting plan was adopted for this Project.
5. Findings were made pursuant to the provisions of CEQA.
6. A Statement of Overriding Considerations was not adopted for this Project.

This is to certify that the record of permit issuance for the Project is available to the general public at the State Water Board, Division of Drinking Water District Office noted above. The MND is available from the lead agency.

Signature:  Date: 6/11/2019
Name: Chi P. Diep Title: District Engineer



EDMUND G. BROWN JR.
GOVERNOR



MATTHEW RODRIGUEZ
SECRETARY FOR
ENVIRONMENTAL PROTECTION

State Water Resources Control Board

TO: Chi P. Diep, District Engineer
Metropolitan District Office
Division of Drinking Water

FROM: Sara Paiva-Lowry, Senior Environmental Scientist: *SP 9/10/18*
Special Project Review Unit
Division of Financial Assistance

Susan Stewart, Environmental Scientist
Special Project Review Unit
Division of Financial Assistance

DATE: September 10, 2018

SUBJECT: WATER SUPPLY PERMIT (PERMIT) FINDINGS FOR CITY OF INGLEWOOD
WATER DEPARTMENT (CITY), NEW WELL NO. 7 PROJECT (PROJECT),
WATER SYSTEM ID NUMBER 1910051

The City is the lead agency pursuant to the California Environmental Quality Act (CEQA) for the proposed Project. The State Water Resources Control Board (State Water Board), as a responsible agency pursuant to CEQA, has reviewed the Mitigated Negative Declaration (MND) prepared by the City, dated September 19, 2014. On October 23, 2014 a Notice of Intent (NOI) was filed with the Los Angeles County Clerk and posted from October 23, 2014 to November 24, 2014 announcing the public hearing and plan to adopt the Draft MND. On November 18, 2014 the Draft MND was adopted by Resolution No. 15-12, including implementation of the proposed mitigation measures. The City developed a Final MND dated November 30, 2014. On December 17, 2014 The City filed a Notice of Determination with the Los Angeles County Clerk.

More than one year after the City adopted the MND, the document was distributed to the public and circulated with the State Clearinghouse (SCH # 2016021083) for a 30-day review period beginning on February 22, 2016 and ending on March 22, 2016. During the public review period one written comment was received from the Department of Transportation. The City filed the MND a second time with the SCH for a 45-day review period beginning on September 21, 2016 and ending on November 4, 2016, and it was sent to the Office of Historic Preservation and the Native American Heritage Commission as reviewing agencies. The Office of Planning Research sent a letter confirming that no state agencies submitted comments during this comment period.

Project Description:

The City proposes to construct a new water production well on a City owned parking lot in an urban area to include:

FELICIA MARCUS, CHAIR | EILEEN SOBECK, EXECUTIVE DIRECTOR

1001 I Street, Sacramento, CA 95814 | Mailing Address: P.O. Box 100, Sacramento, CA 95812-0100 | www.waterboards.ca.gov

1. Demolish existing pavement and remove nine (9) existing trees on the site (*Remove 9-trees: 2@10"-diam, 1@12"-diam, 4@14"-diam, 1@16"-diam, 1@18"-diam*).
2. Construct 12-inch RCP wastewater storm drain (SD) line connecting to LA County 36-inch SD main (permit obtained).
3. Install a 24-foot sound-insulation wall for noise control around the site perimeter for the duration of the Project.
4. Provide for water treatment using two above-ground settling tanks for NPDES compliance during drilling.
5. Drill a 48-inch diameter hole and install a 42" conductor casing 50-feet below ground surface (bgs).
6. Drill a 17 ½-inch pilot bore-hole from 50-feet to 700-feet bgs.
7. Perform downhole geophysical surveying and then isolated aquafer zone testing.
8. Collect samples and send to laboratory for testing.
9. Ream pilot borehole to 38-inch from 50-feet to 350-feet bgs and then ream pilot borehole 30-in from 350-feet to 640-feet.
10. Provide caliper survey and then magnetic deviation survey.
11. Install new 20-inch High-Strength Low Alloy (HSLA) well casing (total 642 feet). 3-inch gravel feeding tube and 2-inch sounding tube.
12. Install Tacna Sand and Gravel pack.
13. Install annular cement/grout seal from 5-feet to 300-feet bgs.
14. Conduct alignment survey.
15. Mechanically develop the well.

Determination:

As a responsible agency, the State Water Board has considered the Project MND dated November 30, 2014 together with all comments and Division of Financial Assistance, Special Project Review Unit staff hereby recommend the following findings for the Project:

- The Project will not result in any significant water quality impacts.
- There are no recommended Permit conditions.

Pursuant to CEQA Guidelines, Section 15096(i), the attached NOD will be filed with the Governor's Office of Planning and Research, State Clearinghouse within five (5) days of issuance of the Permit.

cc: Karen Wong
Associate Sanitary Engineer

APPENDIX 2

Service Area Map
Hydraulic Schematic
Schematic of Sanford Treatment Plant
Treatment Plant Data Sheet

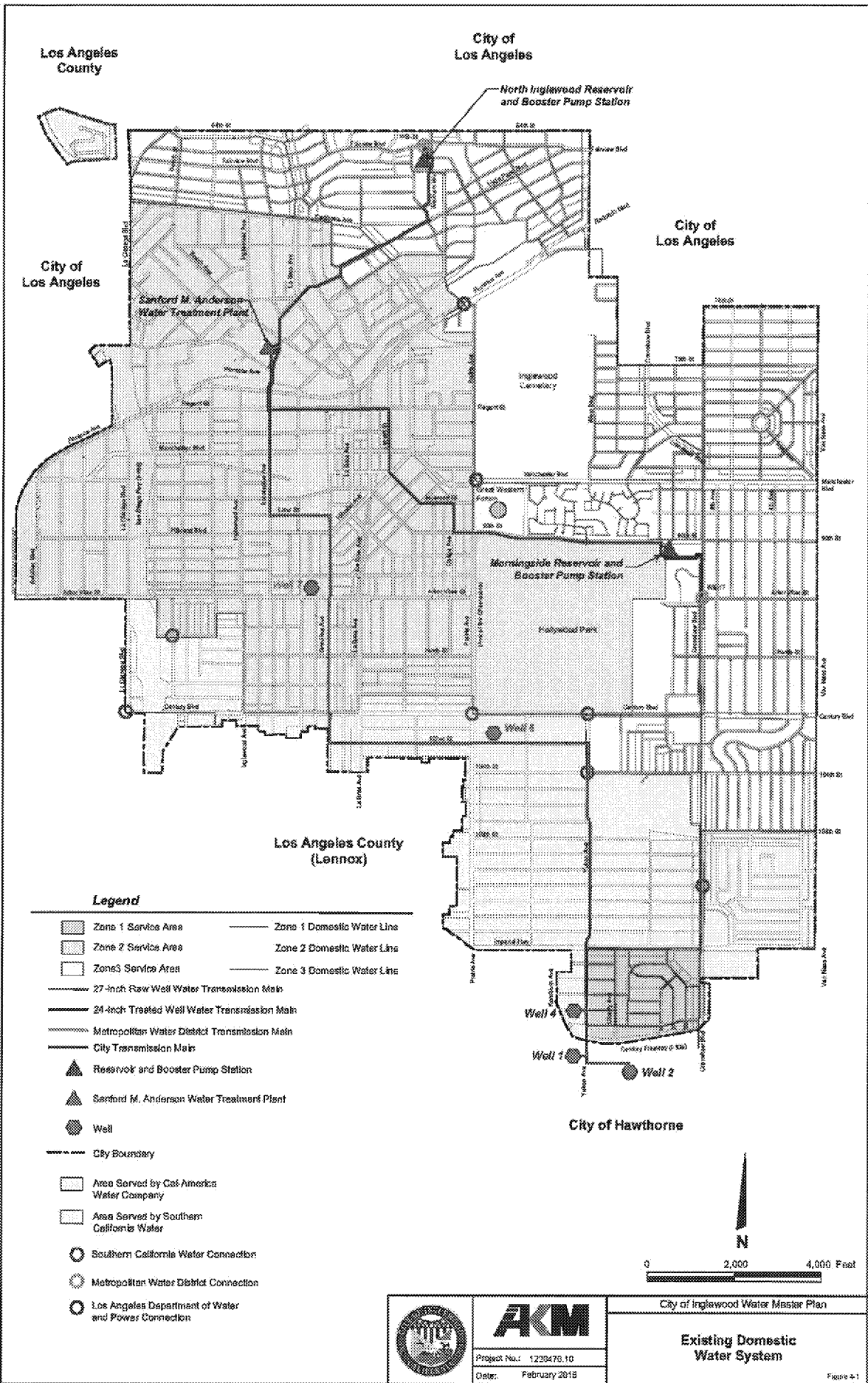

- Legend**
- Zone 1 Service Area
 - Zone 2 Service Area
 - Zone 3 Service Area
 - Zone 1 Domestic Water Line
 - Zone 2 Domestic Water Line
 - Zone 3 Domestic Water Line
 - 27-inch Raw Well Water Transmission Main
 - 24-inch Treated Well Water Transmission Main
 - Metropolitan Water District Transmission Main
 - City Transmission Main
 - Reservoir and Booster Pump Station
 - Sanford M. Anderson Water Treatment Plant
 - Well
 - City Boundary
 - Area Served by Cal-America Water Company
 - Area Served by Southern California Water
 - Southern California Water Connection
 - Metropolitan Water District Connection
 - Los Angeles Department of Water and Power Connection

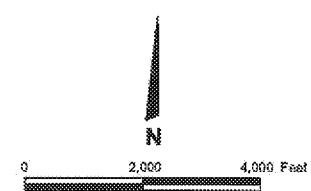

		City of Inglewood Water Master Plan
	Project No.: 1230475.10 Date: February 2015	Existing Domestic Water System

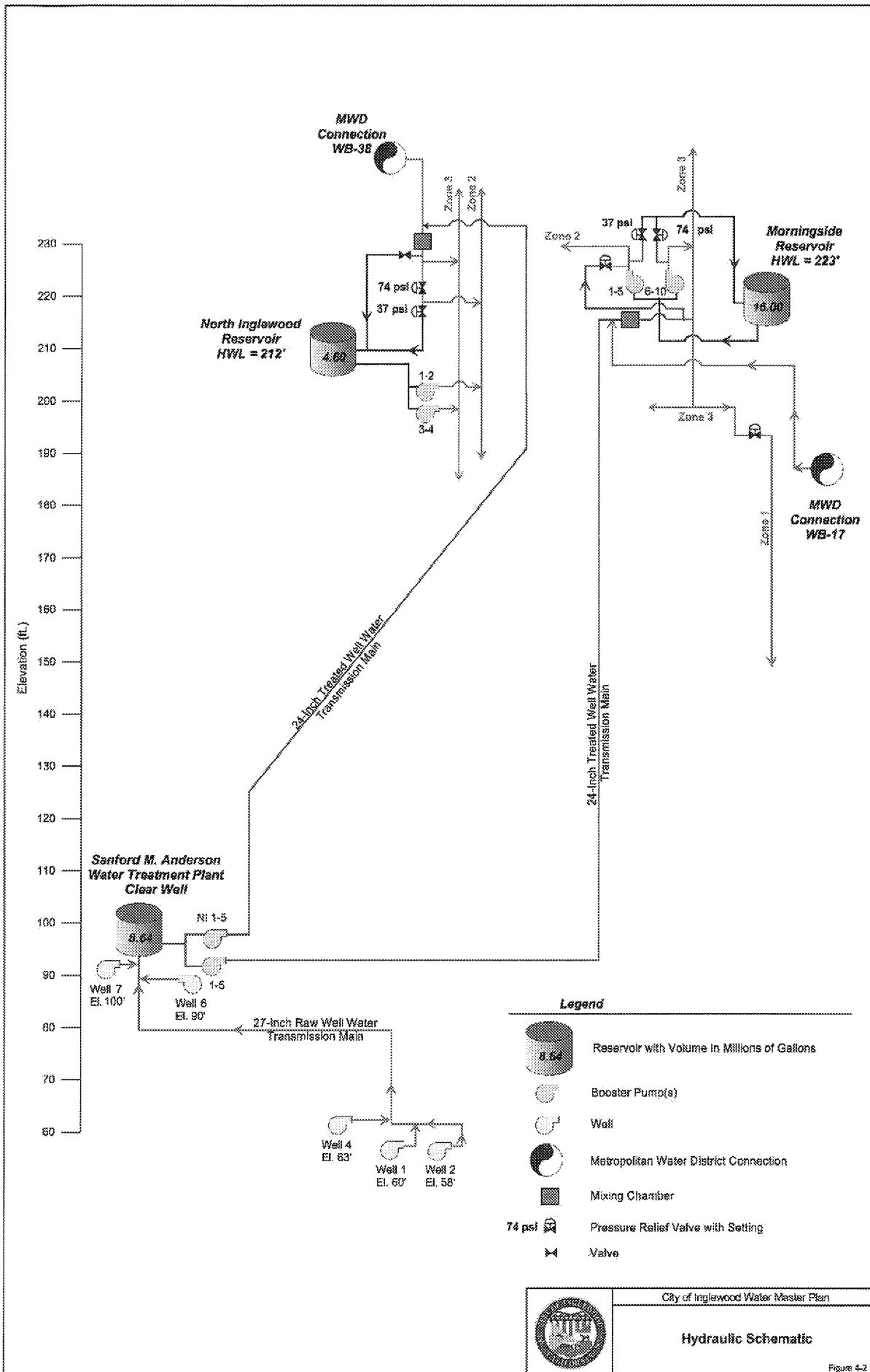

OXIDATION AND PRE-CHLORINATION

CS-4630

CS-4630

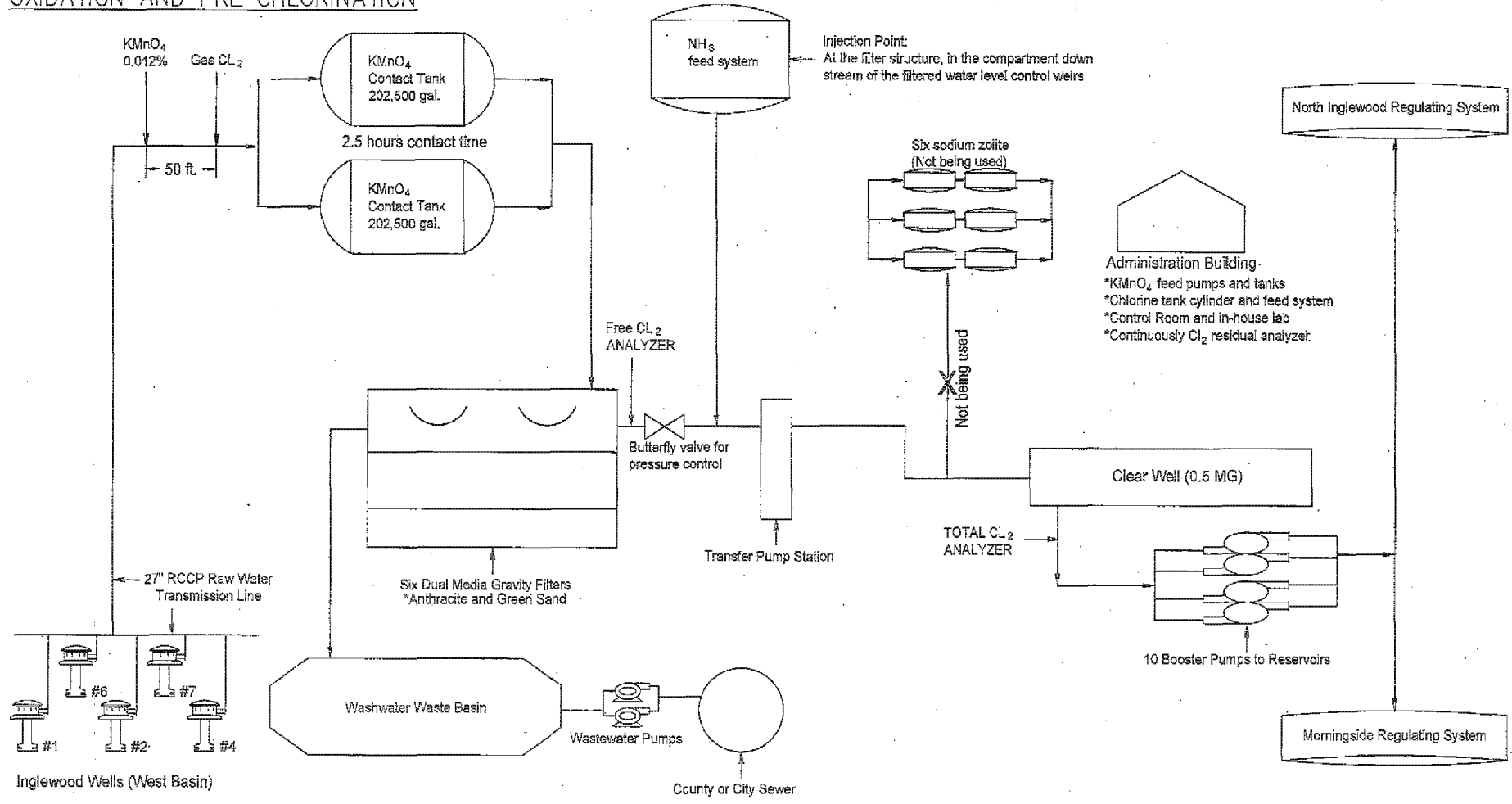

CS-4630

CS-4630

City of Inglewood, System No. 1910051
 Sanford M. Anderson Plant
 FE/Mn Treatment Process Schematic
 Date Updated: May 2019, SWRCB-DDW, Los Angeles Office

**STATE OF CALIFORNIA
DEPARTMENT OF PUBLIC HEALTH
DIVISION OF DRINKING WATER**

IRON AND MANGANESE REMOVAL PLANT DATA

System Name: City of Inglewood **System No.:** 1910051
Source of Information: DPH Files/ System Files
Collected by: Ismael Perez **Date:** July/2018
Name of water treatment plant: Sanford M. Anderson Water Treatment Plant

GENERAL INFORMATION

Plant flow and variations: 2.3 MGD to 5.2 MGD
 Design flow: 8.64 MGD
 Year operation began: 1974
 Frequency plant checked: Daily

Raw Water Pumps

Source	Production capacity	Horse power	Flow variation	Control
Well #1	800 gpm	150 HP	5%	SCADA
Well #2	600 gpm	150 HP	5%	SCADA
Well #4	800 gpm	350 HP	5%	SCADA
Well #6	1500 gpm	200 HP	5%	SCADA
Well #7	1500 GPM	200 HP	5%	SCADA

Type and method of control: Bristol Babcock Equipment/ Telemetry
 Maximum Capacity: 7.3 MGD
 Capacity of each: See Table

CHEMICAL DATA FOR DISINFECTION/OXIDATION

Type: One Ton Chlorine Cylinders
 Purpose: Pre-Chlorination / Post-Chloramination
 Dosage: 16 mg/l
 Is the chemical added continuously? Yes

Chemical Storage

Capacity: 12,000 lbs
 Days of storage: 13 Days
 Chemical form when it is added to the system: Solution
 Points of application: Treatment Plant Headwork's

Feeding and Injection Equipment

Type: Wallace & Tiernan
 Capacity: 2000 lbs
 What determines the dose that will be used? Operational Data & Breakpoint Demand

OTHER CHEMICAL USE

Purpose: Post- Chloramination
 Type: Aqua Ammonia 20%
 Dosage: 5:1 Cl2:NH3-N
 Is the chemical added continuously? Yes

Chemical Storage

Capacity: 1,500 gallon vertical bulk storage tank
 Days of storage: 58 Days
 Chemical form when it is added to the system: Solution
 Points of application: Post- Filtration

Feeding and Injection Equipment

Type: Milton Roy/ Positive Displacement Pumps
 Capacity: 2.8 GPH
 What determines the dose that will be used? Filter Free Chlorine Residual

OTHER CHEMICAL USE

Purpose: Oxidation
 Type: KMnO4
 Dosage 0.07mg/l
 Is the chemical added continuously? Yes

Chemical Storage

Capacity: 4000 gallons
 Days of storage: 110 Days
 Chemical form when it is added to the system: Solution 1.5%
 Points of application: Treatment Plant Headwork's

Feeding and Injection Equipment

Type: Milton Roy/ Positive Displacement Pumps
 Capacity: 3.8 GPH
 What determines the dose that will be used? Influent & Effluent Fe & Mn Concentrations

CHEMICAL MIXING

Type: Steel baffled tanks
 Number: two
 Mixing energy (G): 3- Element FRP 25 degree triple action
 Mixing time/flow: 67 minutes @ 8.64 MGD

FILTERS

Type: Gravity dual Media/Constant Rate Number: 6
 Filter inside dimensions: 11' X 22'
 Describe filter maintenance: Performance Monitoring

Media	Depth	Effective Size	Uniformity Coefficient	Specific Gravity
Greensand	18"	0.3-0.35	<1.60	2.4
Anthracite	18"	0.6-0.8	<1.4	1.6-1.7

Gravel-Number of Layers: 5 Total depth: 15"
 Media area per filter: 242 sq ft Total media area: 1452 sq ft
 Under drain type: PVC Perforated

Filtration Rate at Design Flow:

All filters in service: 4.0 gpm/sq ft
 One filter is not in service: 5.0 gpm/ sq ft
 How is filtration rate controlled: Hydraulically

Filter backwash

What determines the time or interval of backwashing? NTU/ Head Loss/ Hours of Service
 Filter to waste capability? No
 Type of surface wash: Fixed water surface wash
 Surface wash rate: 3.0 gpm/ sq ft Surface wash duration: 8 min
 Source of backwash water: filters in service
 Can spent backwash be visually observed? Yes
 Maximum backwash rate: 16 gpm/ sq ft
 Percent expansion during backwash: 50 %
 Describe backwash cycle: filter inlet valve closes, waste water valve opens, surface wash valve opens, surface wash valve closes, waste water valve closes, filter inlet valve opens.

Waste Washwater Basins

Type of basin: Reinforced concrete rectangular basin
 Number of basins: one Detention time: 24 hours
 Volume of wastewater per backwash: 52,000 gallons
 Washwater disposal or recycling: Disposed to LACSD
 Sludge disposal: LACSD

CLEARWELL

Type: Reinforced concrete rectangular tank Capacity: .834 MGD
 Detention time: 2.31 hours

RELIABILITY FEATURES AND MONITORING

Parameter	Location	Grab Sample (frequency)	Continuous Monitoring	Recording	Alarm	Shutdown
Cl2 Residual	Effluent	Analyzer	Yes	Yes	Yes	
Cl2 Residual	Effluent	Rver4y for hours				
Cl2 Residual	Filters	Analyzer	Yes	Yes	Yes	
Free NH3-N	Effluent	Once a day				
NTU	Effluent	Every for hours				
NTU	Filters	Analyzer	Yes	Yes	Yes	
NTU	Effluent	Analyzer	Yes	Yes	Yes	
Fe	Effluent	Once a day				
Mn	Effluent	Once a day				
Ph	Effluent	Analyzer	Yes	No		
Conductivity	Effluent	Analyzer	Yes	No		
Color	Effluent	Every four hours				

Standby equipment: none
 Standby power: none
 Discussion and Appraisal: None

TREATED WATER QUALITY

Effluent residual: 2.5-3.5 mg/l total chlorine residual
 % of iron reduction: 90% Range of Effluent Iron Level: non-detect to 40ug/l
 % of manganese reduction: 80% Range of Effluent Manganese Level: non- detect to 30ug/l

OPERATIONS

Describe records maintained: Daily operational records of water quality, quantity, and chemical consumption and dosages.

Is operations plan adequate, if not describe needed changes: None

Required level of certification: T-1

Number and level of certified operators: Three T-2, four T-3, one T-4

Constituent:	Monitoring Frequency (continuous/daily/weekly/monthly)
Iron, Manganese, Color, NTU, Odor, Ammonia,	Weekly at plant influent, Monthly at wells
Free and Total residuals, NTU, Color	Every for hours
Combined Residual, Free NH3-N	Daily

APPENDIX 3

Well Diagram
Well Data Sheet
Pump Test Results
Title 22 Test Results
Bacteriological Test Results

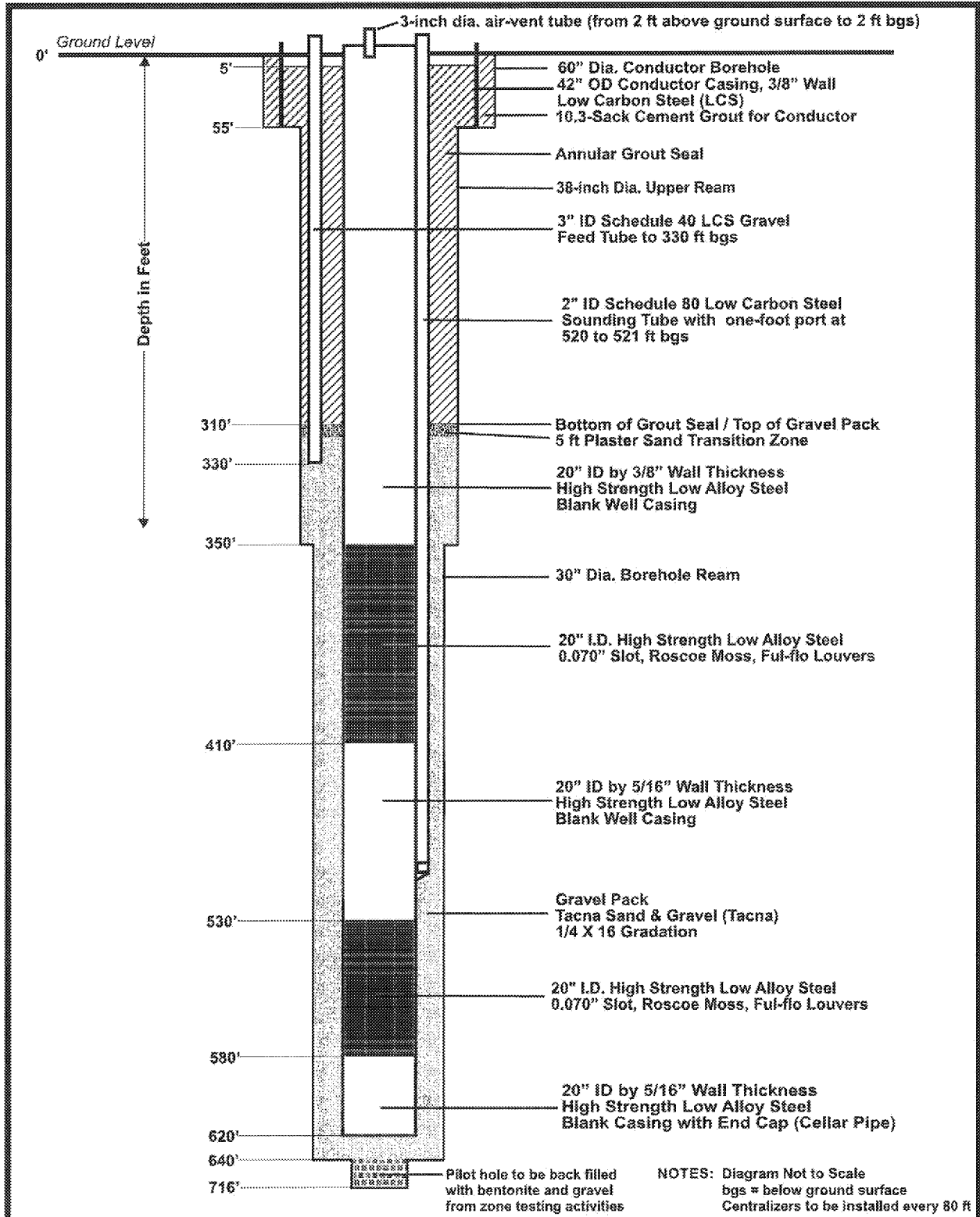

RICHARD C. SLADE & ASSOCIATES LLC
CONSULTING GROUNDWATER GEOLOGISTS
 14051 Burbank Blvd., Suite 300
 Sherman Oaks, CA 91401
 Southern California (818) 506-0418
 Northern California (707) 963-3914

FIGURE 1
FINAL RECOMMENDED
WELL DESIGN DIAGRAM
CITY OF INGLEWOOD WELL NO. 7

Job No. 496-LAS02

April 2018

WELL DATA SHEET (Page 1 of 3)

Complete as much information as possible. Leave blank if information is not available, use N.A. if not applicable.		
* Indicates items required for Source Water Assessment		
** Indicates additional items required for assessments and Ground Water Rule		
	(separate multiple entries in field with semi-colon)	Actual, Estimated or Default?
DATA SHEET GENERAL INFORMATION		
System Name	City of Inglewood	<i>from SWRCB database</i>
System Number	1910051	<i>from SWRCB database</i>
Source of Information (well log, SWRCB/County files, system, etc)	Site Feasibility Report	
Organization Collecting Information (SWRCB, County, System, other)	Other	actual
Date Information Collected/Updated	April 5, 2016	actual
WELL IDENTIFICATION		
* Well Number or Name	Well No. 7	actual
* SWRCB Source Identification Number (FRDS ID No.)	1910051-19	actual
DWR Well Log on File? ("YES" or "NO")	Yes	actual
State Well Number (from DWR)	02S14W33F001S	actual
Well Status (Active, Standby, Inactive)	Active	actual
WELL LOCATION		
Latitude	33.95292	actual
Longitude	-118.35515	actual
Ground Surface Elevation (ft above Mean Sea Level)	105	Estimated
Street Address	101 Arbor Vitae St	actual
Nearest Cross Street	South Grevillea Ave	actual
City	Inglewood	actual
County	Los Angeles	actual
* Neighborhood/Surrounding Area (see Note 1)	Residential	actual
Site plan on file? ("YES" or "NO")	Yes	Pending
DWR Ground Water Basin	Coastal Plain of Los Angeles	actual from DWR
DWR Ground Water Sub-basin	West Coast Basin	actual from DWR
SANITARY CONDITIONS		
** Distance to closest Sewer Line, Sewage Disposal, Septic Tank (ft)	69.60	actual
Distance to Active Wells (ft)	5,200 ft	actual
Distance to Abandoned Wells (ft)	Unknown	actual
Distance to Surface Water (ft)	5 miles	actual
** Size of controlled area around well (square feet)	3,000	actual
* Type of access control to well site (fencing, building, etc)	Fencing	actual
* Surface Seal? (Concrete slab)("YES", "NO" or "UNKNOWN")	Concrete Slab	actual
* Dimensions of concrete slab: Length(ft)/ Width(ft)/ Thick(in)	91/33/1.25	actual
* Within 100 year flood plain? ("YES", "NO" or "UNKNOWN")	No	actual
* Drainage away from well? ("YES" or "NO")	Yes	actual
ENCLOSURE/HOUSING		
Enclosure Type (building, vault, none, etc.)	None	actual
Floor material	Concrete	when completed
Located in Pit? ("YES" or "NO")	No	actual
Pit depth (feet) (if applicable)	--	
WELL CONSTRUCTION		
Date drilled	3/15-3/17/2018	actual
Drilling Method	reverse circulation	actual
Depth of Bore Hole (feet below ground surface)	716	actual
Casing Beginning Depth/Ending Depth(ft below surface); 2nd Casing Beginning Depth/Ending Depth; 3rd Casing, etc.	0 to 620	actual
Casing Diameter (inches); 2nd Casing Diameter; 3rd Casing, etc.	20	actual
Casing Material; 2nd Casing Material; 3rd Casing, etc.	High Strength, Low Alloy	actual
WELL CONSTRUCTION (continued)		
Conductor casing used? ("YES", "NO" or "UNKNOWN") (See Note 2)	Yes	actual
Conductor casing removed? ("YES", "NO" or "UNKNOWN")	No	actual
* Depth to highest perforations/screens (ft below surface) (or "UNKNOWN")	352	actual

WELL DATA SHEET (Page 2 of 3)

<i>Complete as much information as possible. Leave blank if information is not available, use N.A. if not applicable.</i>		
<i>* Indicates items required for Source Water Assessment</i>		
<i>** Indicates additional items required for assessments and Ground Water Rule</i>		
Screened Interval Beginning Depth/Ending Depth (ft below surface); 2nd Screened Interval Beg. Depth/Ending Depth; 3rd Screened Interval, etc.	352 to 410 532 to 581	<i>actual</i>
* Total length of screened interval (ft) <i>(default = 10% pump capacity in gpm) (or "UNKNOWN")</i>	197	<i>actual</i>
* Annular Seal? ("YES", "NO" or "UNKNOWN") <i>(See Note 3)</i>	Yes	<i>actual</i>
* Depth of Annular Seal (ft)	310	<i>actual</i>
Material of Annular Seal <i>(cement grout, bentonite, etc.)</i>	cement grout	<i>actual</i>
Gravel pack, Depth to top (ft below ground surface)	310 to 636	<i>actual</i>
Total length of gravel pack (ft)	326	<i>estimated</i>
AQUIFER		
* Aquifer Materials <i>(list all that apply: sand, silt, clay, gravel, rock, fractured rock)</i>	clay, silt and sand	<i>actual</i>
* Effective porosity (decimal percent) <i>(default = 0.2) (or "UNKNOWN")</i>	0.2	<i>default</i>
* Confining layer (Impervious Strata) above aquifer? ("YES", "NO" or "UNKNOWN")	Yes	<i>actual</i>
Thickness of confining layer, if known (ft)	180 (combined total to 340')	<i>actual</i>
Depth to confining layer, if known (ft below ground)	80	<i>actual</i>
* Static water level (ft below ground surface)	112	<i>actual</i>
Static water level measurement: Date/Method	5/18/2018/Sounder	<i>actual</i>
Pumping water level (ft below ground surface)	208	<i>actual</i>
Pumping water level measurement: Date/Method	5/22/2018/Sounder	<i>actual</i>
WELL PRODUCTION		
Well Yield (gpm)	1,500	<i>actual</i>
Well Yield Based On (i.e., pump test, etc.)	Pumping Test	<i>actual</i>
Date measured	5/22/2018	<i>actual</i>
Is the well metered? ("YES" or "NO")	Yes	<i>actual</i>
Production (gallons per year)	693,000,000	<i>estimated</i>
Frequency of Use (hours/year)	462,000	<i>estimated</i>
Typical pumping duration (hours/day)	22 hr /day	<i>estimated</i>
PUMP		
Make	Goulds	<i>actual</i>
Type	Submersible	<i>actual</i>
Size (hp)	200	<i>actual</i>
* Capacity (gpm)	1,500	<i>actual</i>
Depth to suction intake (ft below ground surface)	300	<i>actual</i>
Lubrication Type	Water (Submersible)	<i>actual</i>
Type of Power: <i>(i.e., electric, diesel, etc.)</i>	Electric	<i>actual</i>
Auxiliary power available? ("YES" or "NO")	No	<i>actual</i>
Operation controlled by: <i>(i.e., level in tank, pressure, etc.)</i>	SCADA	<i>actual</i>
Pump to Waste capability? ("YES" or "NO")	Yes	<i>actual</i>
Discharges to: <i>(i.e., distribution system, storage, etc.)</i>	Water Treatment Plant	<i>actual</i>
REMARKS AND DEFECTS (use additional sheets as necessary)		

Layne Christensen Company

Date: 5-14-18 Page 1

Customer: CITY of INGLEWOOD # 7 WELL

Job No. 46675

12" MOCROM
Motor GAZ X 1000
18152 000
8298 000

Static level 119.1 Feet
Airline depth 318.0 Feet
TOP PERF 3500'

Hours/Day 4.0
Total hours 4.0
G.P.D. 146,000

Operator: PORTER

P.E. 32793

Time	RPM	GPM	Pumping Level	Draw-down	Engine RPM	Specific Capacity	Comments	NTU	PAU	TSS
2:30										
2:30		FIRST	START	TO	TANKS		RED & LITE MUDDY 1 MIN			
2:33	^{2.5} 88.3 RPM						CLEAR	17.1		
2:40	^{3.0} 106.0 RPM	800	167.8'	48.7'	942	16.42	CLEAR VERY CLEAR	4.5		
2:50	^{4.0} 106.0 RPM	1250	190.9'	71.8'	1045	17.40	CLEAR			
2:59		START	AFTER	1 SURGE			CLEAR	4.41		
3:14	^{1.8} 136.6 RPM	1400	207.1'	88.0'	1126	15.90	VERY CLEAR	0.94		
3:20		START	AFTER	3 SURGES			CLEAR	16.5		
3:40	^{6.0} 111.3 RPM	1800	242.9'	123.8'	1304	14.53	CLEAR	3.6		
4:05		START	AFTER	4 SURGES			CLEAR	15.4		
4:25	^{3.6} 95.4 RPM	2000	244.0'	124.9'	1360	16.01	CLEAR	4.2		
4:40		START	AFTER	4 SURGES			CLEAR	16.7		
5:00	^{2.4} 76.8 RPM	2350	251.2'	132.1'	1440	18.51	CLEAR	4.6		
5:15		START	AFTER	4 SURGES			CLEAR	17.0		
5:35	^{2.3} 66.2 RPM	2460	252.0'	132.9'	1465	18.51	CLEAR	4.8		
5:40		START	AFTER	3 SURGES			CLEAR	16.3		
6:00	^{2.1} 55.6 RPM	2500	253.0'	133.9'	1469	18.67	CLEAR	7.2		
6:50		SHUT	DOWN	PICK	UP	TOOLS				
		SAND NEEDS WORK TURBIDITY UNDER CONTROL. WELL YIELD COMING IN GOOD. WON'T TAKE 60 HRS.								

Layne Christensen Company

Date: 5-15-18 Page 2

Customer: CITY of INGLEWOOD #7 WELL

Job No. 27-46675

12" MCCROM

Meter GALX 1200
18298
18900

Static level 123.9 Feet
 Airline depth 318.0 Feet
 TOP PERF. 300'

Hours/Page 10.0

Total hours 14.0

G.P.D. 602,000

Operator: PORTER

P.E. 32793

Time	PRM	GPM	Pumping Level	Draw-Down	Engine RPM	Specific Capacity	Comments	NTU	FAO	TSS
8:00							START TO WASTE			
8:20	3.4 90.1 PPM	1500	200.1'	76.2'	1100	19.68	15" SEC DISCHARGED CLEAR	12.1		
8:40							START AFTER 4 SURGES			
9:00	2.3 60.9 PPM	1428	202.5'	78.6'	1100	18.16	CLEAR	14.1		
9:20							START AFTER 3 SURGES			
9:40	2.0 PPM 53.8 PPM	2025	239.4'	115.5'	1300	17.53	CLEAR	8.9		
10:00							SHUT DOWN REPAIRS TO DISCHARGE			
11:15							UP & RUNNING			
11:35	1.4 48 PPM	2040	240.6'	116.7'	1320	17.40	CLEAR	4.21		
11:40							START AFTER 3 SURGES			
12:00	1.8 46.8 PPM	2177	266.0'	142.1'	1410	15.32	CLEAR	9.8		
12:12							START AFTER 4 SURGES			
12:32	1.7 45 PPM	2312	277.5'	153.6'	1450	15.05	CLEAR	9.2		
12:44							START AFTER 7 SURGES			
1:04	2.3 60.9 PPM	2475	285.6'	161.7'	1500	15.30	AT 2500 MAIN HOLE OVER FLOWS 25 GPM.	10.3		
1:25	4.2 32.4 PPM	2460	290.2'	167.2'	1500	14.70	LEFT RUNNING SAND TESTS CLEAR	7.2		
2:07							START AFTER 10 SURGES			
2:32	2.8 59.6 PPM	2123	245.2'	121.3'	1298	17.50	CLEAR	5.9		
3:05							START AFTER 10 SURGES			
3:35	1.7 22.3 PPM	1734	225.3'	101.4'	1206	17.10	CLEAR	9.61		
3:57							START AFTER 4 SURGES			
4:25	1.7 32.1 PPM	1735	225.3'	101.4'	1206	17.14	"	8.2		
4:32							START AFTER 3 SURGES			
4:47	1.7 32.1	1736	225.1'	101.2'	1206	17.18	"	6.1		
4:59							START AFTER 3 SURGES			
5:15	1.1	1740	225.1'	101.2'	1206	17.19	"	7.2		
5:25							START AFTER 3 SURGES			
5:50	1.1	1742	225.1'	101.2'	1206	17.21	CLEAR	6.8		
6:00							SURGE & SHUT DOWN SAND IS GETTING BETTER	4.0		

Layne Christensen Company

Date: 5-16-18 Page 3

Customer: CITY of TINGLEWOOD #7 WELL
12" M. DEPTH

Job No. 27-46675

Meter X
18900000

Static level 128.0' Feet
 Airline depth 318.0' Feet
 TOP PERF. 350'

Hours/Page _____
 Total hours _____
 G.P.D. _____

Operator: PORTER P.E. 32793

PUMP SILTS FROM WELL DEVELOPMENT

Time	R.P.M.	G.P.M.	Pumping Level	Draw-down	Engine R.P.M.	Specific Capacity	Comments	NTU	
								FAU	TSS
7:00							START UP WARM UP TEST EQUIPMENT		
7:05							START TO WASTE		
7:20		1690	218.6	90.6'	1206	18.65	CLEAR @ 2MIN	4.5	13.3
7:30	1.8 PPM 40.2 PPM	1604	220.0	92.0'	1206	17.43	CLEAR	7.1	8.0
8:05							START AFTER 4 SURGES		
8:20	1.5 PPM 53.0 PPM	1724	215.4'	87.4'	1206	19.72	CLEAR	5.15	4.04
8:25							START AFTER 2 SURGES		
8:40	1.0 PPM 35.0 PPM	1760	216.8	88.8'	1225	19.81	CLEAR	8.6	4.8
8:43							START AFTER 2 SURGES		
8:58	1.9 PPM 31.2 PPM	1860	229.0	101.0'	1259	18.42	CLEAR	5.1	4.0
9:04							START AFTER 3 SURGES		
9:20	1.1 PPM 36.4 PPM	1890	230.2	102.2'	1264	18.49	CLEAR	5.9	4.9
9:25							START AFTER 3 SURGES		
9:40	1.4 PPM 37.1 PPM	2000	240.6'	112.6'	1326	17.76	CLEAR T.D.B. 328 3/4 D.H. 6.5 TEMP 73°F F.P. 656 MS/cm	6.58	4.4
9:51							START AFTER 3 SURGES		
10:06	1.9 PPM 31.8 PPM	2004	241.7	113.7'	1322	17.62	CLEAR	7.9	6.0
10:10							START AFTER 3 SURGES		
10:25	1.9 PPM 31.8 PPM	2004	241.7'	113.7'	1326	17.62	CLEAR	7.6	4.1
10:45							START AFTER 3 SURGES		
10:00	1.2 PPM 42.4 PPM	2004	241.7'	113.7'	1326	17.62	CLEAR LET RW TO CHECK SAND YIELD	3.0	2.4
11:15	1.3 PPM 3.5 PPM	2004	243.6'	115.6'	1326	17.33	SAND GOOD AFTER 15 MW	2.4	2.4
11:19							START AFTER 2 SURGES		
11:34	1.4 PPM 49.4 PPM	2004	241.6'	113.6'	1326	17.64	CLEAR	2.9	2.9
11:40							START AFTER 2 SURGES		
11:55	1.4 PPM 49.4 PPM	2004	241.6'	113.6'	1326	17.64	CLEAR	4.2	4.9
11:57							START AFTER 2 SURGES		
12:12	1.35 PPM 47.7 PPM	2004	241.6	113.6	1326	17.64	"	6.9	4.0
12:17							START AFTER 2 SURGES		
12:32	1.35 PPM 47.7 PPM	2004	241.6	113.6	1326	17.64	"	6.9	3.9
12:35							START WATER IS GRAVEL SHOOT	2.9	2.9
12:45	1.3 PPM 68.9 PPM							4.0	4.0
12:50	1.3 PPM 3.9 PPM	2004	241.6	113.6	1326	17.68		1982.000	

Layne Christensen Company

Date: 5-16-18 Page 4

Customer: CITY of INGELWOOD #7 WELL

Job No. 27-46675

12" MICROM.

Meter X
 18900
 19052

Static level 128.0' Feet
 Airline depth 318.0' Feet
 TOP PERF 350'

P.E. 32793

Hours/Page 11.5
 Total hours 25.8
 O.P.D. 952,000

Operator: PORTER

WORKING ON SILTS.

Time	PPM	GPM	Pumping Level	Draw-down	Engine R.P.M.	Specific Capacity	Comments	FAU	TSS
12:30							FROM LAST PAGE		
1:00			START AFTER STOP	START	5 G.P.M.		DOWN GRAVEL PACK	6.9	
1:15	.7 24.7 PPM	2004	241.5'	113.5'	1326	17.65	CLEAR	2.4	
1:25			STOP START				CLEAR	4.93	
1:35	.6 21.3 PPM						CLEAR	2.00	
1:45	.5 16.5 PPM						CLEAR	1.87	
1:55	.05 2.0 PPM	2008	248.6'	120.6'	1320	18.60	CLEAR	4.3	
1:58			STOP START				10 MINS OF SAND THAN TAPERS GFR TO 2.3 PPM	2.5	
2:13	.8 28.26 PPM	2022	246.2'	118.2'	1335	17.10	CLEAR	1.95	
2:30	.15 4.6 PPM	2026	249.4'	121.4'	1339	16.68	CLEAR	4.3	
2:35			STOP START				CLEAR	2.2	
2:55	.63 17.22 PPM	2004	241.3'	113.3'	1326	17.68	CLEAR	4.1	
2:57			STOP START				CLEAR	1.6	
3:12	.25 8.8 PPM	1750	216.3'	88.3'	1220	19.81	CLEAR	2.9	
3:14			STOP START HIGHER FLO				CLEAR	4.4	
3:29	.5 17.66 PPM	2025	249.3'	121.3'	1332	16.69	CLEAR	2.6	
3:31			STOP START				CLEAR	4.6	
3:46	.38 19.4 PPM	2025	249.3'	121.3'	1331	16.69	CLEAR	2.2	
3:48			STOP START				CLEAR	1.8	
4:03	.55 19.4 PPM	2025	249.3'	121.3'	1330	16.69	CLEAR	4.0	
4:13	.05 2.6 PPM	2025	249.5'	121.5'	1330	16.69	CLEAR	2.0	
4:15			STOP START	REDUCED FLO			CLEAR	5.5	
4:35	.3 7.9 PPM	1730	215.8'	87.8'	1205	19.70	CLEAR	2.3	
4:40			START STOP	HIGHER Q			CLEAR	4.9	
5:00	1.8 26.5 PPM	2150	260.7'	132.7'	1380	16.20	CLEAR	3.0	
5:05			START STOP	HIGHER FLO			CLEAR	3.8	
5:20	.9 31.8 PPM	2240	269.6'	141.6'	1420	15.81	CLEAR	1.75	
5:25			STOP START	LOWER Q			CLEAR	3.6	
5:45	.45 11.9 PPM	1990	243.6'	115.6'	1315	17.21	CLEAR	1.5	
6:00			STOP & RESTART	AFTER 10 MINS			CLEAR		
6:20	.28 7.42 PPM	1550	205.8'	77.8'	1180	19.92	CLEAR		
6:30			SHUT DOWN						

Layne Christensen Company

Date: 5-17-18 Page 5

Customer: CITY OF INCEWOOD #7 WELL

Job No. 46675

12" MCCORM
Motor SNL X 1000
19852000

Static level 128.8' Feet
Airline depth 318.0' Feet
TOP PERF. 350.0' P.E. # 32793

Hours/Page _____
Total hours _____
G.P.D. _____

Operator: PORTER

WORKING ON SAND.

Time	PPM	GPM	Pumping Level	Draw-down	Engine RPM	Specific Capacity	Comments	FAU	TSS
7:00							START TEST ENGINE WARM UP SURGE WELL		
7:20							TO WASTE AFTER 4 SURGES CLEAR		
7:22	37.7 ^{1.5} PPM	1650	200.7'	78.9'	1145	22.94	"	4.96	
7:30	33.1 ^{2.3} PPM	1615	204.2'	75.7'	1145	21.41	"	3.07	
7:40	33.3 ^{2.2} PPM	1604	203.1'	79.3'	1145	20.22	"	2.73	
7:50	1.5 ^{2.2} PPM	1530	210.4'	81.6'	1145	18.76	"	1.16	
8:00	9.5 ^{2.3} PPM	1528	211.4'	81.6'	1145	18.72	"		
8:09							START AFTER 1 SURGE		4.1
8:24	21.2 ^{2.6} PPM	1765	217.1'	88.3'	1220	19.98	"	2.6	
8:28							START AFTER 1 SURGE		4.26
8:43	28.28 ^{2.8} PPM	1760	217.8'	89.0'	1215	19.77	ADJ. SAND TESTER INCREASE FLD. 3.6 P.M.	2.03	
8:46							START AFTER 1 SURGE		4.22
9:01	28.24 ^{2.8} PPM	1760	217.8'	89.0'	1215	19.77	"	2.00	
9:03							START AFTER 1 SURGE		4.05
9:18	25.3 ^{1.0} PPM	1790	222.1'	93.3'	1228	19.18	"	1.98	
9:22							START AFTER 1 SURGE		4.6
9:37	42.4 ^{1.2} PPM	2004	241.6'	112.8'	1320	17.76	"	2.3	
9:40							START AFTER 2 SURGES		4.4
9:55	39.8 ^{1.1} PPM	2004	241.6'	112.8'	1320	17.76	"	2.2	
10:00							START AFTER 2 SURGES		4.2
10:15	35.33 ^{1.0} PPM	2004	241.6'	112.8'	1322	17.76	"	2.2	
10:20							START AFTER 2 SURGES		4.1
10:35	33.5 ^{1.0} PPM	2009	241.6'	112.8'	1326	17.81	"	2.0	
10:40							START AFTER 2 SURGES		3.9
10:50	35.33 ^{1.0} PPM	2010	241.8'	113.0'	1328	17.78	"	2.0	
11:00							START AFTER 2 SURGES HIGHER @		5.52
11:15	70.6 ^{2.0} PPM	2250	252.1'	128.8'	1400	18.24	"	3.2	
11:30	10.6 ^{2.3} PPM	2281	261.4'	132.6'	1433	17.20	"	2.2	
11:45	1.7 ^{2.35} PPM	2300	264.8'	136.0'	1433	16.91	"	2.0	
11:50							START AFTER 2 SURGES		5.7
12:10	35.2 ^{2.1} PPM	2300	263.9'	135.1'	1433	17.02	"	2.2	
12:13							START AFTER 2 SURGES		5.60

Layne Christensen Company

Date: 5-17-18 Page 6

Customer: CITY of INGLEWOOD #7 WELL

Job No. 46675

12" MCORON
 Meterial X 1000
 19852.000
 20594.000

Static level 128.8 Feet
 Airline depth 318.0 Feet
 TOP PERF. 350.0' RE #32793

Hours/Page 10.5
 Total hours 36.0
 G.P.D. 742,000

Operator: PORTER

WORKING ON SAND

NTU

Time	PPM	G.P.M.	Pumping Level	Draw-down	Engine R.P.M.	Specific Capacity	Comments	FAU	TSS
12:15	1.8 PPM	2281	261.4'	132.6'	1400	17.20	CLEAR	2.3	
12:33	47.7 PPM						CLEAR		
12:38			START AFTER 1 SURGE				"	5.3	
12:58	46.3 PPM	2280	261.3'	132.5'	1400	17.20	"	2.4	
1:00			START AFTER 1 SURGE				"	5.4	
1:20	1.6 PPM	2280	261.9'	133.1'	1400	17.12	"	2.2	
1:27			START AFTER 1 SURGE				"	5.2	
1:47	1.4 PPM	2275	261.7'	132.9'	1398	17.11	"	2.0	
2:04	37.1 PPM		START AFTER 1 SURGE				"	5.0	
2:24	1.35 PPM	2270	261.1'	132.3'	1380	17.15	"	2.0	
2:30	35.7 PPM		START AFTER 1 SURGE				"	3.4	
2:50	1.2 PPM	2250	260.1'	131.3'	1370	17.13	"	1.9	
3:00			STARTS AFTER 1 SURGE				"	3.2	
3:20	1.3 PPM	2250	260.2'	131.4'	1400	17.12	"	1.8	
3:25	34.4 PPM		START AFTER 1 SURGE		LOW FLOW		"	2.02	
3:45	5.4 PPM	1034	188.6'	59.8'	1072	17.29	"	1.6	
3:50			START AFTER 1 SURGE				"	2.79	
4:12	2.6 PPM	816	172.4'	43.6'	1004	18.72	"	1.7	
4:15			SHUT DOWN FOR STEP TEST SETUP.						
5:00			WORKING ON TRANS VALVES						
5:30			OFF SITE						
			SAND LOOKING VERY GOOD						
							STEPS		
						1200	1000	4 HRS	EACH
						1700	1500		
						2000	1800		

Layne Christensen Company

Date: 5-18-18 Page 7

Customer: CITY of INGLEWOOD #7 WELL

Job No. 27-46675

12" McCROM
Meter GALK 1000

Static level 128.8' Feet
Airline depth 318.0' Feet
TOP PERF. 350.0' P.E. # 32793

Hours/Page _____
Total hours _____
G.P.D. _____

20594000
Operator: PORTER EVANS

STEP TEST #1

NTU

Time	R.P.M.	G.P.M.	Pumping Level	Draw-down	Engine R.P.M.	Specific Capacity	Comments	FAU	TSS
7:00					1045		CLEAR	20594000	
7:02	21.2 PPM	1340	179.15'	50.35'	1046	26.61		20594000	
7:04	27.7 PPM	1330	182.9'	54.1'	1047	24.58		20594000	
7:06	37.9 PPM	1320	184.55'	55.7'	1048	23.69			
7:08	39.9 PPM	1315	185.9'	57.1'	1050	23.02	CRYSTAL CLEAR		
7:10	43 PPM	1310	186.91'	58.11'	1052	22.54		20607320	
7:15	50 PPM	1292	188.47'	59.6'	1052	21.67		20613780	
7:20	53 PPM	1240	189.21'	60.41'	1052	20.52		20619980	
7:25	53 PPM	1208	189.71'	60.91'	1052	19.83		20626000	
7:30	53 PPM	1286	193.64'	64.84'	1068	19.83		20652430	
7:35	53 PPM	1290	194.21'	65.41'	1068	19.72		20638880	
7:40	53 PPM	1300	194.67'	65.87'	1068	19.79		20645440	
7:50	53 PPM	1268	195.3'	66.5'	1068	19.06		20652080	
8:00	53 PPM	1280	195.75'	66.95'	1068	19.11		20670920	
8:10	53 PPM	1250	196.07'	67.27'	1068	18.58		20683440	
8:20	53 PPM	1258	196.3'	67.5'	1068	18.63		20696000	
8:30	53 PPM	1260	196.5'	67.7'	1068	18.61		20708670	
8:40	53 PPM	1250	196.63'	67.83'	1068	18.42	NTU .98	20721100	
8:50	53 PPM	1248	196.85'	68.05'	1068	18.33	1267.1 AVG. (2 hrs)	20746000	
9:15	53 PPM	1248	197.05'	68.25'	1068	18.28		20764800	
9:30	53 PPM	1246	197.23'	68.43'	1068	18.20		20783300	
9:45	53 PPM	1240	197.54'	68.7'	1068	18.04	P.H. 6.8	20801900	
10:00	53 PPM	1230	197.8'	69.0'	1068	17.82	TEMP 21.2°C E.C. 667 mskm T.D.S. 332 g/L	20820200	
10:30	53 PPM	1228	197.97'	69.17'	1068	17.75		20837100	
11:00	53 PPM	1226	198.01'	69.21'	1068	17.71	CRYSTAL CLEAR	20853800	
GALLONS PUMPED 299889.9 • AVG. FLOW 1249.5 W 40 W H.P. = 62.3 • C.H.P. = 90.1 • 80 LBS DISCHARGE PRESSURE DESIGN 386 T.P.H. @ 1206 gpm = (119.5 W 40 W) = 173.1 B.H.P.									

Customer: CITY OF INGLEWOOD

12" MC CORM

Meter GALX 1000

Static level 128.8 Feet

Airline depth 318.0 Feet

TOP PERF. 350.0

7 WELL

Date: 5-18-18 Page 8

Job No. # 46675

Operator: PORTER EVANS

P.E. 32793

Hours/Page _____

Total hours _____

G.P.D. _____

STEP #2

Time	P.P.M.	G.P.M.	Pumping Level	Draw-down	Engine R.P.M.	Specific Capacity	Comments	FAU	TSS
11:00							FROM LAST SHEET	20893	390
11:02	5.15 2 PPM	1580	211.55	82.75	1150	19.09	CRY. CLEAR	20897	600
11:04	5.31 5.2 PPM	1570	213.6	84.8	1164	18.51	" "	20900	050
11:06	5.34 5.0 PPM	1560	214.43	85.61	1164	18.22	" "	20903	270
11:08	5.56 5.2 PPM	1556	214.9	86.1	1164	18.07		20906	310
11:10	5.58 5.3 PPM	1550	215.27	86.47	1164	17.92		20909	400
11:15	2.1 PPM 6.5	1620	218.53	89.75	1179	18.05		20917	500
11:20	5.3 PPM 6.8	1612	219.89	91.09	1187	17.69		20925	550
11:25	3.0 PPM 6.9	1650	220.7	91.9	1190	17.95		20933	610
11:30	1.0 PPM 6.9	1610	221.01	92.21	1196	17.46		20941	800
11:35	5.3 PPM 6.9	1635	222.90	94.1	1196	17.37		20950	000
11:40	3 PPM 7.0	1632	222.97	94.17	1196	17.33		20958	150
11:45	2.1 PPM 7.8	1630	223.21	94.41	1196	17.26		20966	300
11:50	3.0 PPM 7.8	1628	223.4	94.6	1196	17.20		20974	000
12:00	5.24 PPM 8.0	1630	223.7	94.9	1196	17.17	1618.5 Ave.	20991	000
12:10	1.06 PPM 8.1	1638	223.95	95.15	1196	17.21		21007	400
12:20	5.53 PPM 8.1	1640	224.18	95.38	1196	17.19		21023	900
12:30	8.1 8.1	1634	224.3	95.5	1196	17.10		21040	000
12:45	8.1 8.2	1636	224.55	95.75	1196	17.08		21044	200
1:00	1.3 PPM 8.3	1630	224.8	96.0	1196	16.97	CRY. CLEAR	21089	000
1:15	3.5 PPM 8.3	1627	224.88	96.08	1196	16.93	" "	21113	400
1:30	3.5 PPM 8.3	1626	224.88	96.08	1196	16.92	ATG .90	21137	780
1:45	3.5 PPM 8.6	1621	225.16	96.36	1196	16.82	T.O.S. 350 g/L PH. 6.8	21160	800
2:00	3.5 PPM 8.8	1621	225.31	96.51	1196	16.79	TEMP 74° E.C. 703 ms/cm	21186	400
2:30	3.5 PPM 8.9	1620	225.61	96.81	1196	16.73		21235	000
3:00	1.8 PPM 8.9	1620	225.86	97.06	1196	16.69		21283	600
TOTAL GALLONS PUMPED 389,710. AVG. G.P.M. FLO 1623.8.									
A.C. FT. PER DAY 7,15710. W+O+W H.P. = 92.4. B.H.P. = 133.9									
KWH 99.89. KWH/A.C. FT. = 334.9.									

Layne Christensen Company

Date: 5-18-18 Page 9

Customer: CITY OF INGLEWOOD #7 WELL
12" MACROM

Job No. 46675

Meter: N-X 1000
2059400
21818930

Static level 128.8' Feet
 Airline depth 318.0' Feet
 TOP PERF 3500' P/E 32793

Hours/Page 12.0
 Total hours 48.0
 G.P.D. 1,224,950

Operator: PORTER EVANS STEP #3

Time	PRM	G.P.M.	Pumping Level	Draw-down	Engine R.P.M.	Specific Capacity	Comments	FAU	TSS
3:00	START FROM	LAST	STREET						
							CRYSTAL CLEAR	21283	600
3:02	1.15 68.9 PPM	2280	255.5'	126.7	1410	17.99	"	21287	580
3:04	1.83 79.3 PPM	2278	258.8'	130.0	1410	17.52	"	21291	980
3:06	1.88 79.5 PPM	2276	260.15'	131.35'	1410	17.32	"	21297	370
3:08	1.81 79.5 PPM	2260	261.28'	132.48'	1410	17.05	"	21302	000
3:10	1.56 10.6 PPM	2238	262.04'	133.24'	1410	16.60	"	21306	580
3:15	1.6 4.2 PPM	2238	263.57'	134.77'	1410	16.60	"	21317	570
3:20	1.7 1.0 PPM	2250	264.49'	135.69'	1410	16.38	"	21328	980
3:25	1.80 1 PPM	2240	265.05'	136.25'	1410	16.44	"	21346	050
3:30	1.83 5.3 PPM	2248	265.6'	136.8'	1410	16.43	"	21351	900
3:35	1.90 5.3 PPM	2255	266.05'	137.25'	1410	16.39		21362	780
3:40	2.0 10.6 PPM	2250	266.35'	137.55'	1410	16.35		21373	910
3:50	2.1 5.3 PPM	2235	266.81'	138.01'	1410	16.19		21396	250
4:00	2.2 5.3 PPM	2238	267.33'	138.53'	1410	16.15		21418	500
4:10	2.25 2.6 PPM	2237	267.7'	138.9'	1410	16.10		21446	980
4:20	2.3 2.65 PPM	2238	268.03'	139.23'	1410	16.07		21463	890
4:30	2.35 2.65 PPM	2236	268.4'	139.6'	1410	16.01		21481	620
4:45	2.40 1.76 PPM	2234	268.7'	139.9'	1410	15.96	NTA .53	21518	990
5:00	2.5 3.5 PPM	2230	269.0'	140.2'	1410	15.90	P.H. 6.8	21557	410
5:15	2.55 1.7 PPM	2227	269.3'	140.5'	1410	15.85	74°F E.C. .764 m/s/cm T.D.S. 352 g/L	21585	800
5:30	2.6 1.7 PPM	2225	269.58'	140.78'	1410	15.80	CRYSTAL CLEAR	21618	020
5:45	2.65 1.7 PPM	2226	269.83'	141.03'	1410	15.78		21653	500
6:00	2.7 1.7 PPM	2224	270.03'	141.2'	1410	15.76		21685	900
6:30	2.8 1.7 PPM	2220	270.55'	141.75'	1410	15.66		21702	410
7:00	2.9 1.7 PPM	2218	270.91'	142.11'	1410	15.60		21818	750
TOTAL GALLONS PUMPED			535,350.		AVG FLO 2230.6 g.p.m.				
AC. FT. / DAY			= 9.85757.		W.T.O.U. H.P. = 151.7 = B.H.P. = 219.8				
164.0 KW.			399.3 KWH / AC. FT.		SYSTEM PRESSURE NOT IN				
CALCULATIONS.			WELL PRODUCES SMALL AMT. SILTS @						
THIS FLOW.			SHOULD BE GONE WITH CONTINUOUS.						
CONDITIONS @			1500 G.P.M.						

Customer: CITY of INGLEWOOD WELL #7
 12" MCDROM

Job No. 27-46675

Material X 1000
 21819500

Static level 127.7 Feet
 Airline depth 318.0 Feet
 TOP PERF 350'
 SUCTION @ 340'

Hours/Day 7.0
 Total hours 55.0
 G.P.D. _____

Operator: PORTER

CONTINUOUS RUN

Time	PPM	GPM	Pumping Level	Draw-down	Engine RPM	Specific Capacity	Comments	PAU TES
10:00		START	CONTINUOUS		1060		CLEAR	21819500
10:02	.03 7.95 PPM	1500	181.2'	53.5'	1070	28.03	"	21822100
10:04	.07 10.6 PPM	1500	191.2'	63.5'	1132	23.62	"	21823090
10:06	.11 7.95 PPM	1500	194.4'	66.7'	1134	22.48	"	21827980
10:08	.15 5.3 PPM	1500	196.75'	69.05'	1136	21.71	"	21831600
10:10	.15 7.9 PPM	1500	199.3'	71.6'	1139	20.94	CRYSTAL CLEAR	21834000
10:15	.20 2.25 PPM	1505	201.6'	73.9'	1140	20.36		21841300
10:20	.24 2.65 PPM	1510	204.2'	76.5'	1142	19.73		21849030
10:25	.23 1.3 PPM	1520	205.05'	77.35'	1148	19.65		21856080
10:35	.26 1.3 PPM	1526	208.27'	80.57'	1153	18.94		21871980
10:40	.27 1.3 PPM	1526	208.78'	81.08'	1156	18.74		21879420
10:50	.27 2.25 PPM	1532	212.68'	84.98'	1160	18.02		21895080
11:00	.28 2.60 PPM	1545	213.27'	85.57'	1172	18.05		21910810
11:10	.28 2.65 PPM	1550	213.87'	86.17'	1172	17.98		21926300
11:20	.29 2.65 PPM	1550	214.26'	86.56'	1172	17.90		21941910
11:30	.29 2.65 PPM	1550	214.68'	86.98'	1172	17.82		21957300
11:45	.29	1530	215.20'	87.5'	1172	17.37		21980200
12:00	.29 2.53 PPM	1542	215.62'	87.92'	1172	17.53		22003390
12:15	.29	1530	215.99'	88.29'	1172	17.32	(1532.4 AVG. FLO)	22027300
12:30	.29	1530	216.25'	88.55'	1172	17.27		22049270
12:45	.29	1529	216.53'	88.83'	1172	17.21	NTU .80	
1:00	.29	1527	216.71'	89.01'	1172	17.15	P.H. 6.8 T.D.S. 350 g/l TEMP. 74%	22093090
1:30	.30 1 PPM	1525	217.2'	89.5'	1172	17.03		22140890
2:00	.3	1523	217.3'	89.6'	1172	16.99	CRY CLEAR	22180370
2:30	.3	1522	217.9'	90.2'	1172	16.87	"	22233400
3:00	.3	1520	218.1'	90.4'	1172	16.81	"	22279000
3:30	.3	1556	220.6'	92.9'	1182	16.74	"	22323900
4:00	.3	1541	221.0'	93.3'	1185	16.50	"	22370110
4:30	.31 2.27 PPM	1550	221.3'	93.6'	1185	16.55		22410700
5:00	.31	1546	221.37'	93.67'	1185	16.49		22463190

Layne Christensen Company

Date: 5-21-18 Page 11

Customer: CITY of INGLEWOOD WELL # 7

Job No. 46675

12" MCCROM
WaterGALX 1000

Static level 127.7 Feet
Airline depth 318.0 Feet
TOP PERF. 350'
PUMP SECTION 340'

Hours/Page 15.6
Total hours 70
G.P.D. _____

Operator: PORTER EVANS

CONTINUOUS FLOW

22463140

Time	RPM	GPM	Pumping Level	Draw-down	Engine RPM	Specific Capacity	Comments	FAU	TSS
5:00	.31	1546	221.37	93.67	1185	16.49	CRYSTAL CLEAR NTU 74	22	122
5:30	.31	1545	221.55	93.85	1185	16.46		22	509490
6:00	.31	1546	221.75	94.05	1185	16.43	(1534.3 AVG.)	22	535970
6:30	.31	1550	221.88	94.18	1188	16.45		22	662500
7:00	.31	1544	222.0	94.3	1188	16.37		22	648420
7:30	.32	1544	222.10	94.46	1188	16.34		22	697780
8:00	Trace	1540	222.26	94.56	1188	16.28	1.49 NTU	22	740950
8:30	Trace	1535	222.36	94.66	1188	16.21		22	87000
9:00	Trace	1541	222.46	94.76	1188	16.26		22	83730
9:30	Trace	1541	222.57	94.87	1188	16.24	1.15 NTU	22	87980
10:00	Trace	1533	222.65	94.95	1188	16.14		22	92550
10:30	Trace	1525	222.75	95.05	1188	16.04	Sand Accumulation Very Minute.	22	971250
11:00	Trace	1538	222.8	95.1	1188	16.17		23	017400
11:30	Trace	1536	222.9	95.2	1188	16.13		23	063800
12:00	Trace	1533	222.97	95.27	1188	16.09	5-22-18 NEW DAY	23	10950
12:30	Trace	1533	223.05	95.35	1188	16.07		23	155500
1:00	Trace	1525	223.11	95.41	1188	15.98	1.19 NTU	23	201250
1:30	Trace	1528	223.17	95.47	1188	16.00		23	247100
2:00	Trace	1534	223.22	95.52	1188	16.05		23	293125
2:30	Trace	1529	223.37	95.67	1188	15.98		23	339000
3:00	Trace	1525	223.35	95.65	1188	15.94		23	389750
3:30	Trace	1533	223.4	95.7	1188	16.01		23	438755
4:00	Trace	1524	223.44	95.74	1188	15.91		23	476500
4:30	Trace	1533	223.5	95.8	1188	16.0		23	522580
5:00	Trace	1516.6	223.54	95.84	1188	15.81		23	568000
5:30	Trace	1533	223.59	95.89	1188	15.98		23	614000
6:00	Trace	1546	223.65	95.95	1188	15.79		23	659500
6:30	Trace	1533	223.67	95.97	1188	15.97	1.27 NTU	23	705500
7:00	Trace	1521	223.7	96	1188	15.84		23	751150
7:30	Trace	1528	223.73	96.03	1188	15.91		23	797000
8:00	Trace	1526	223.76	96.06	1188	15.88		23	84260
8:30	Trace								

Loyne Christensen Company

Date: 5-22-18 Page 12

Customer: CITY of INGLEWOOD # 7 WELL

Job No. 46675

12" MFCROM
MOTORCALX 1000

Static level 177.7' Feet
Airline depth 318.0' Feet

Hours/Day 9.0
Total hours 79.0
G.P.D. 2,844.500

Operator: PORTER EVANS

CONTINUOUS

Time	P.P.M.	G.A.M.	Pumping Level	Draw-down	Engine R.P.M.	Specific Capacity	Comments	FAU	TES
8:00	.48 TRACE	1526	223.76	96.06	1188	15.88	FROM LAST PAGE	2389	260
8:30	.34 Trace	1530	223.79	96.09	1188	15.92	CRY CLEAR	2388	500
9:01	.48 TRACE	1528	223.81	96.11	1188	15.89	" "	2393	580
9:30	.40 .029 MP	1527	223.84	96.14	1188	15.88	P.H. 6.8 NTA 1.39	2398	015
10:00	.40	1526	223.88	96.18	1188	15.86	T.D.S. - 401 g/L EC. - 801 μS/cm TEMP 74°F	2402	027
10:00	220.5	770	GALLONS (1531.8 G.P.M. AVG.)				TAKING THIEF SAMPLES		
10:30	.40	1526	223.92	96.22	1188	15.85	CRY CLEAR	2407	070
11:00	TRACE	1526	223.95	96.25	1188	15.85	" "	2411	690
11:30	.40 TRACE	1524	223.99	96.29	1188	15.82	" "	2416	220
12:00	.40 TRACE	1523	224.01	96.31	1188	15.81	" "	2420	830
1:00	.40 TRACE	1522	224.07	96.37	1188	15.79	SAMPLES COMPLETE	2429	630
1:30	.40 TRACE	1522	224.10	96.4	1188	15.78	" "	2434	290
2:30	.40 TRACE	1521	224.13	96.43	1188	15.77	" "	2443	
3:00	.40 TRACE	1521	224.16	96.46	1188	15.76	" "	2443	550
3:30	.40 TRACE	1520	224.19	96.49	1188	15.75	" "	2448	180
4:00	.40 TRAC	1520	224.21	96.51	1188	15.74	(1522.5 AVG. 6 HRS)	2457	380
4:30	.40	1520	224.23	96.53	1188	15.74	" "	2461	980
5:00	.40	1520	224.25	96.55	1188	15.74	* TITLE # 22 SAMPLES TAKEN.	2464	000
THE CONTINUOUS RUN 31 HRS. AVG. FLO 1529.3 G.P.M.									

30150

662

181

600

Customer: CITY of INGLEWOOD #7 WELL

Job No. 27-46675

12" MACROM

Meter CALX 1000

Static level 127.7' Feet

Airline depth 318.0' Feet

Hours/Day 3.0

Total hours 82.0

G.P.D. _____

Operator: PORTER

RECOVERY

Time	P.P.H.	G.P.H.	Pumping Level	Draw-down	Engine P.P.H.	Specific Capacity	Comments	FAU	TSB
5:00							CONTINUOUS SHUT DOWN END of		
5:02			163.8'						
5:04			158.1'						
5:06			154.3'						
5:08			151.6'						
5:10			150.0'						
5:15			147.6'						
5:20			145.6'						
5:25			144.18'						
5:30			143.05'						
5:35			142.25'						
5:40			141.45'						
5:50			140.2'						
6:00			139.3'						
6:10			138.6'						
6:20			138.0'						
6:30			137.4'						
6:45			137.1'						
7:00			136.3'						
7:35			135.6'						
7:36			135.8'						
7:45			135.1'						
8:00			135.0'						

Work Orders: 9D30052

Report Date: 6/04/2019

Project: Inglewood, City of, 1910051

Received Date: 5/2/2019

Turnaround Time: Normal

Phones: 310.660.6246

Fax: (310) 217-2414

P.O. #: W2773

Attn: Cheryl A. Ross

Billing Code:

Client: West Basin Municipal Water District
17140 South Avalon Blvd., Suite 210
Carson, CA 90746-1218

EPA-UCMR #CA00211 • HW-DOH # • ISO 17025 #L2457.01 • LACSD #10143 • NELAP-CA #04229CA • NELAP-OR #4047 •
NJ-DEP #CA015 • NV-DEP #NAC 445A • SCAQMD #93LA1006

This is a complete final report. The information in this report applies to the samples analyzed in accordance with the chain-of-custody document. Weck Laboratories certifies that the test results meet all requirements of TNI unless noted by qualifiers or written in the Case Narrative. This analytical report must be reproduced in its entirety.

Dear Cheryl A. Ross,

Enclosed are the results of analyses for samples received 5/02/19 with the Chain-of-Custody document. The samples were received in good condition, at 5.9 °C and on ice. All analyses met the method criteria except as noted in the case narrative or in the report with data qualifiers.

Reviewed by:

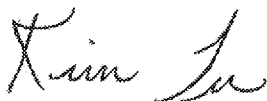

Kim G. Tu
Project Manager





Certificate of Analysis

FINAL REPORT

WECK LABORATORIES, INC.

West Basin Municipal Water District
17140 South Avalon Blvd., Suite 210
Carson, CA 90746-1218

Project Number: Inglewood, City of, 1910051

Reported:
06/04/2019 14:58

Project Manager: Cheryl A. Ross

Sample Summary

Sample Name	Sampled By	Lab ID	Matrix	Sampled	Qualifiers
Well 7, 1910051-019, Alias: 3961A	Allan Goldberg (wecklabs)	9D30052-05	Water	05/02/19 09:55	

Analyses Accreditation Summary

Analyte	CAS #	Not By NELAP	By ANAB
<i>SRL 524M-TCP in Water</i> 1,2,3-Trichloropropane	96-18-4	✓	



Certificate of Analysis

FINAL REPORT

WECK LABORATORIES, INC.

West Basin Municipal Water District
17140 South Avalon Blvd., Suite 210
Carson, CA 90746-1218

Project Number: Inglewood, City of, 1910051

Reported:
06/04/2019 14:58

Project Manager: Cheryl A. Ross

Sample Results

Sample: Well 7, 1910051-019, Alias: 3961A
9D30052-05 (Water) Sampled: 05/02/19 9:55 by Allan Goldberg (wecklabs)

Analyte	Result	MRL	Units	Dfl	Analyzed	Qualifier
Chlorinated Acids Herbicides by GC/ECD						
Method: EPA 515.4	Batch ID: W9E0290	Instr: GC08	Prepared: 05/07/19 08:28	Analyst: gc08		
2,4,5-T	ND	0.20	ug/l	1	05/11/19 01:28	
2,4,5-TP (Silvex)	ND	0.20	ug/l	1	05/11/19 01:28	
2,4-D	ND	0.40	ug/l	1	05/11/19 01:28	
2,4-DB	ND	2.0	ug/l	1	05/11/19 01:28	
3,5-Dichlorobenzoic acid	ND	1.0	ug/l	1	05/11/19 01:28	
Acifluorfen	ND	0.40	ug/l	1	05/11/19 01:28	
Bentazon	ND	2.0	ug/l	1	05/11/19 01:28	
Chloramben	ND	1.0	ug/l	1	05/11/19 01:28	
Dalapon	ND	0.40	ug/l	1	05/11/19 01:28	
DCPA	ND	0.10	ug/l	1	05/11/19 01:28	
Dicamba	ND	0.60	ug/l	1	05/11/19 01:28	
Dichloroprop	ND	0.30	ug/l	1	05/11/19 01:28	
Dinoseb	ND	0.40	ug/l	1	05/11/19 01:28	
Pentachlorophenol	ND	0.20	ug/l	1	05/11/19 01:28	
Picloram	ND	0.60	ug/l	1	05/11/19 01:28	
Surrogate(s)						
2,4-DCAA	103%	Conc: 10.3	70-130		05/11/19 01:28	

Chlorinated Pesticides and/or PCBs by GC/ECD						
Method: EPA 508	Batch ID: W9E0324	Instr: GC07	Prepared: 05/07/19 12:06	Analyst: adm		
Toxaphene	ND	1.0	ug/l	1	05/10/19 13:44	
Surrogate(s)						
Decachlorobiphenyl	80%	Conc: 0.0795	70-130		05/10/19 13:44	
Tetrachloro-meta-xylene	89%	Conc: 0.0886	70-130		05/10/19 13:44	

Conventional Chemistry/Physical Parameters by APHA/EPA/ASTM Methods						
Method: EPA 353.2	Batch ID: W9E0126	Instr: AA01	Prepared: 05/02/19 15:53	Analyst: MAT		
Nitrate as N	ND	0.20	mg/l	1	05/02/19 17:12	

Diquat and Paraquat by EPA 549.2						
Method: EPA 549.2	Batch ID: W9E0211	Instr: LC11	Prepared: 05/06/19 08:33	Analyst: jna		
Diquat	ND	4.0	ug/l	1	05/18/19 16:58	

Endothall By EPA 548.1						
Method: EPA 548.1	Batch ID: W9E0212	Instr: GCMS06	Prepared: 05/06/19 08:36	Analyst: rmr		
Endothall	ND	45	ug/l	1	05/08/19 08:31	

Glyphosate by EPA 547						
Method: EPA 547	Batch ID: W9E0554	Instr: LC10	Prepared: 05/09/19 16:52	Analyst: jna		
Glyphosate	ND	5.0	ug/l	1	05/09/19 19:42	

Hexavalent Chromium by IC						
9D30052						



Certificate of Analysis

FINAL REPORT

WECK LABORATORIES, INC.

West Basin Municipal Water District
17140 South Avalon Blvd., Suite 210
Carson, CA 90746-1218

Project Number: Inglewood, City of, 1910051

Reported:
06/04/2019 14:58

Project Manager: Cheryl A. Ross

Sample Results

(Continued)

Sample: Well 7, 1910051-019, Alias: 3961A
9D30052-05 (Water)

Sampled: 05/02/19 9:55 by Allan Goldberg (wecklabs)
(Continued)

Analyte	Result	MRL	Units	DII	Analyzed	Qualifier
Hexavalent Chromium by IC (Continued)						
Method: EPA 218.6 Chromium 6+	Batch ID: W9E0214 Instr: LC13 ND	Prepared: 05/06/19 08:41 0.020	ug/l	1	Analyst: jna 05/08/19 12:10	
Low Level 1,2,3-TCP by SRL Method, P&T, GC/MS SIM						
Method: SRL 524M-TCP 1,2,3-Trichloropropane	Batch ID: W9E0154 Instr: GCMS04 ND	Prepared: 05/03/19 10:40 0.0050	ug/l	1	Analyst: erf 05/03/19 16:56	
Perchlorate by EPA 314.0						
Method: EPA 314.0 Perchlorate	Batch ID: W9E0363 Instr: LC08_Chan ND	Prepared: 05/07/19 15:03 2.0	ug/l	1	Analyst: jan 05/08/19 03:26	
Radiological Parameters by APHA/EPA Methods						
Method: EPA 200.8 Uranium Rad	Batch ID: W9E0309 Instr: ICPMS02 ND	Prepared: 05/07/19 10:15 0.13	pCi/L	1	Analyst: jea 05/07/19 17:55	
Method: SM 7110C Gross Alpha	Batch ID: W9E0201 Instr: RAD01 1.08	Prepared: 05/04/19 07:56 pCi/L		1	Analyst: cic 05/07/19 08:04	
Uncertainty: 0.124 MDA: 0.033						
Semivolatile Organic Compounds by GC/MS						
Method: EPA 525.2 Alachlor	Batch ID: W9E0137 Instr: GCMS16 ND	Prepared: 05/03/19 08:20 0.10	ug/l	1	Analyst: rmr 05/06/19 18:29	
Atrazine	ND	0.10	ug/l	1	05/06/19 18:29	
Benzo (a) pyrene	ND	0.10	ug/l	1	05/06/19 18:29	
Bis(2-ethylhexyl)adipate	ND	5.0	ug/l	1	05/06/19 18:29	
Bis(2-ethylhexyl)phthalate	ND	3.0	ug/l	1	05/06/19 18:29	
Bromacil	ND	0.50	ug/l	1	05/06/19 18:29	
Butachlor	ND	0.10	ug/l	1	05/06/19 18:29	
Captan	ND	1.0	ug/l	1	05/06/19 18:29	
Chlorpropham	ND	0.10	ug/l	1	05/06/19 18:29	
Cyanazine	ND	0.10	ug/l	1	05/06/19 18:29	
Diazinon	ND	0.10	ug/l	1	05/06/19 18:29	
Dimethoate	ND	0.20	ug/l	1	05/06/19 18:29	
Diphenamid	ND	0.10	ug/l	1	05/06/19 18:29	
Disulfoton	ND	0.10	ug/l	1	05/06/19 18:29	
EPTC	ND	0.10	ug/l	1	05/06/19 18:29	
Metolachlor	ND	0.10	ug/l	1	05/06/19 18:29	
Metribuzin	ND	0.10	ug/l	1	05/06/19 18:29	
Molinate	ND	0.10	ug/l	1	05/06/19 18:29	
Prometon	ND	0.10	ug/l	1	05/06/19 18:29	
Prometryn	ND	0.10	ug/l	1	05/06/19 18:29	
Simazine	ND	0.10	ug/l	1	05/06/19 18:29	

9D30052

Page 4 of 20

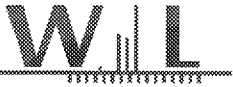

Certificate of Analysis

FINAL REPORT

WECK LABORATORIES, INC.

West Basin Municipal Water District
17140 South Avation Blvd., Suite 210
Carson, CA 90746-1218

Project Number: Inglewood, City of, 1910051

Reported:
06/04/2019 14:58

Project Manager: Cheryl A. Ross

Sample Results

(Continued)

Sample: Well 7, 1910051-019, Alias: 3961A
9030052-05 (Water)
Sampled: 05/02/19 9:55 by Allan Goldberg (wecklabs)
(Continued)

Analyte	Result	MRL	Units	DFI	Analyzed	Qualifier
Semivolatile Organic Compounds by GC/MS (Continued)						
Method: EPA 525.2	Batch ID: W9E0137	Instr: GCMS16	Prepared: 05/03/19 08:20	Analyst: rnr		
Terbacil	ND	2.0	ug/l	1	05/06/19 18:29	
Thiobencarb	ND	0.10	ug/l	1	05/06/19 18:29	
Trithion	ND	0.10	ug/l	1	05/06/19 18:29	
<i>Surrogate(s)</i>						
1,3-Dimethyl-2-nitrobenzene	97% Conc: 4.84	70-130			05/06/19 18:29	
Perylene-d12	101% Conc: 5.05	50-120			05/06/19 18:29	
Triphenyl phosphate	119% Conc: 5.95	70-130			05/06/19 18:29	

Semivolatile Organics - Low Level by Tandem GC/MS/MS

Method: EPA 1613B	Batch ID: W9E0229	Instr: GCMS15	Prepared: 05/07/19 09:35	Analyst: EFC		
2,3,7,8-TCDD (Dioxin)	ND	5.00	pg/l	1	05/14/19 15:08	

Volatile Organic Compounds by P&T and GC/MS

Method: EPA 524.2	Batch ID: W9E0132	Instr: GCMS00	Prepared: 05/03/19 08:21	Analyst: rdt		
1,1,1,2-Tetrachloroethane	ND	0.50	ug/l	1	05/03/19 13:01	
1,1,1-Trichloroethane	ND	0.50	ug/l	1	05/03/19 13:01	
1,1,2,2-Tetrachloroethane	ND	0.50	ug/l	1	05/03/19 13:01	
1,1,2-Trichloroethane	ND	0.50	ug/l	1	05/03/19 13:01	
1,1-Dichloroethane	ND	0.50	ug/l	1	05/03/19 13:01	
1,1-Dichloroethene	ND	0.50	ug/l	1	05/03/19 13:01	
1,1-Dichloropropene	ND	0.50	ug/l	1	05/03/19 13:01	
1,2,3-Trichlorobenzene	ND	0.50	ug/l	1	05/03/19 13:01	
1,2,4-Trichlorobenzene	ND	0.50	ug/l	1	05/03/19 13:01	
1,2,4-Trimethylbenzene	ND	0.50	ug/l	1	05/03/19 13:01	
1,2-Dichloroethane	ND	0.50	ug/l	1	05/03/19 13:01	
1,2-Dichloropropane	ND	0.50	ug/l	1	05/03/19 13:01	
1,3,5-Trimethylbenzene	ND	0.50	ug/l	1	05/03/19 13:01	
1,3-Dichloropropane	ND	0.50	ug/l	1	05/03/19 13:01	
1,3-Dichloropropene, Total	ND	0.50	ug/l	1	05/03/19 13:01	
2,2-Dichloropropane	ND	0.50	ug/l	1	05/03/19 13:01	
2-Butanone	ND	5.0	ug/l	1	05/03/19 13:01	
2-Chlorotoluene	ND	0.50	ug/l	1	05/03/19 13:01	
2-Hexanone	ND	5.0	ug/l	1	05/03/19 13:01	
4-Chlorotoluene	ND	0.50	ug/l	1	05/03/19 13:01	
4-Methyl-2-pentanone	ND	5.0	ug/l	1	05/03/19 13:01	
Benzene	ND	0.50	ug/l	1	05/03/19 13:01	
Bromobenzene	ND	0.50	ug/l	1	05/03/19 13:01	
Bromochloromethane	ND	0.50	ug/l	1	05/03/19 13:01	



Certificate of Analysis

FINAL REPORT

WECK LABORATORIES, INC.

West Basin Municipal Water District
17140 South Avalon Blvd., Suite 210
Carson, CA 90746-1218

Project Number: Inglewood, City of, 1910051

Reported:
06/04/2019 14:58

Project Manager: Cheryl A. Ross

Sample Results

(Continued)

Sample: Well 7, 1910051-019, Alias: 3961A
9D30052-05 (Water)

Sampled: 05/02/19 9:55 by Allan Goldberg (wecklabs)
(Continued)

Analyte	Result	MRL	Units	Dil	Analyzed	Qualifier
Volatile Organic Compounds by P&T and GC/MS (Continued)						
Method: EPA 524.2	Batch ID: W9E0132	Instr: GCM508	Prepared: 05/03/19 08:21	Analyst: rdt		
Bromodichloromethane	ND	0.50	ug/l	1	05/03/19 13:01	
Bromoform	ND	0.50	ug/l	1	05/03/19 13:01	
Bromomethane	ND	0.50	ug/l	1	05/03/19 13:01	
Carbon tetrachloride	ND	0.50	ug/l	1	05/03/19 13:01	
Chlorobenzene	ND	0.50	ug/l	1	05/03/19 13:01	
Chloroethane	ND	0.50	ug/l	1	05/03/19 13:01	
Chloroform	ND	0.50	ug/l	1	05/03/19 13:01	
Chloromethane	ND	0.50	ug/l	1	05/03/19 13:01	
cis-1,2-Dichloroethene	ND	0.50	ug/l	1	05/03/19 13:01	
cis-1,3-Dichloropropene	ND	0.50	ug/l	1	05/03/19 13:01	
Dibromochloromethane	ND	0.50	ug/l	1	05/03/19 13:01	
Dibromomethane	ND	0.50	ug/l	1	05/03/19 13:01	
Dichlorodifluoromethane (Freon 12)	ND	0.50	ug/l	1	05/03/19 13:01	
Di-isopropyl ether	ND	2.0	ug/l	1	05/03/19 13:01	
Ethyl tert-butyl ether	ND	2.0	ug/l	1	05/03/19 13:01	
Ethylbenzene	ND	0.50	ug/l	1	05/03/19 13:01	
Freon 113	ND	5.0	ug/l	1	05/03/19 13:01	
Hexachlorobutadiene	ND	0.50	ug/l	1	05/03/19 13:01	
Isopropylbenzene	ND	0.50	ug/l	1	05/03/19 13:01	
m,p-Xylene	ND	0.50	ug/l	1	05/03/19 13:01	
m-Dichlorobenzene	ND	0.50	ug/l	1	05/03/19 13:01	
Methyl tert-butyl ether (MTBE)	ND	2.0	ug/l	1	05/03/19 13:01	
Methylene chloride	ND	0.50	ug/l	1	05/03/19 13:01	
Naphthalene	ND	0.50	ug/l	1	05/03/19 13:01	
n-Butylbenzene	ND	0.50	ug/l	1	05/03/19 13:01	
n-Propylbenzene	ND	0.50	ug/l	1	05/03/19 13:01	
o-Dichlorobenzene	ND	0.50	ug/l	1	05/03/19 13:01	
o-Xylene	ND	0.50	ug/l	1	05/03/19 13:01	
p-Dichlorobenzene	ND	0.50	ug/l	1	05/03/19 13:01	
p-Isopropyltoluene	ND	0.50	ug/l	1	05/03/19 13:01	
sec-Butylbenzene	ND	0.50	ug/l	1	05/03/19 13:01	
Styrene	ND	0.50	ug/l	1	05/03/19 13:01	
Tert-amyl methyl ether	ND	2.0	ug/l	1	05/03/19 13:01	
tert-Butylbenzene	ND	0.50	ug/l	1	05/03/19 13:01	
Tetrachloroethene	ND	0.50	ug/l	1	05/03/19 13:01	
THMs, Total	ND	2.0	ug/l	1	05/03/19 13:01	

9D30052

Page 6 of 28



Certificate of Analysis

FINAL REPORT

WECK LABORATORIES, INC.

West Basin Municipal Water District
17140 South Avalon Blvd., Suite 210
Carson, CA 90746-1218

Project Number: Inglewood, City of, 1910051

Reported:
06/04/2019 14:58

Project Manager: Cheryl A. Ross

Sample Results

(Continued)

Sample: Well 7, 1910051-019, Alias: 3961A
9D30052-05 (Water)

Sampled: 05/02/19 9:55 by Allan Goldberg (wecklabs)
(Continued)

Analyte	Result	MRL	Units	Dil	Analyzed	Qualifier
Method: EPA 524.2						
Batch ID: W9E0132						
Instr: GCMS08						
Prepared: 05/03/19 08:21						
Analyst: rdt						
Toluene	ND	0.50	ug/l	1	05/03/19 13:01	
trans-1,2-Dichloroethene	ND	0.50	ug/l	1	05/03/19 13:01	
trans-1,3-Dichloropropene	ND	0.50	ug/l	1	05/03/19 13:01	
Trichloroethene	ND	0.50	ug/l	1	05/03/19 13:01	
Trichlorofluoromethane	ND	0.50	ug/l	1	05/03/19 13:01	
Vinyl chloride	ND	0.50	ug/l	1	05/03/19 13:01	
Xylenes, Total	ND	1.0	ug/l	1	05/03/19 13:01	
<i>Surrogate(s)</i>						
1,2-Dichlorobenzene-d4	98% Conc: 9.81	70-130			05/03/19 13:01	
4-Bromofluorobenzene	93% Conc: 9.34	70-130			05/03/19 13:01	

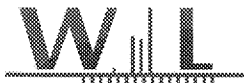

Certificate of Analysis

FINAL REPORT

WECK LABORATORIES, INC.

West Basin Municipal Water District
17140 South Avalon Blvd., Suite 210
Carson, CA 90746-1218

Project Number: Inglewood, City of, 1910051

Reported:
06/04/2019 14:58

Project Manager: Cheryl A. Ross

Sample Results LA Testing - EMSL Analytical, Inc. CA-ELAP #2283, Non-NELAP

Sample: Well 7, 1910051-019
9D30052-05 (Water)

Sampled: 05/02/19 9:55 by Allan Goldberg (wecklabs)

Analyte	Result	MRL	Units	DB	Analyzed	Qualifier
Subcontracted Analyses						
Method: EPA 100.2	Batch ID:	Prepared: 05/03/19 13:50				Analyst: _SUB
Asbestos	ND	0.19	MFL	1	05/15/19	



Certificate of Analysis

FINAL REPORT

WECK LABORATORIES, INC.

West Basin Municipal Water District
17140 South Avalon Blvd., Suite 210
Carson, CA 90746-1218

Project Number: Inglewood, City of, 1910051

Reported:
06/04/2019 14:58

Project Manager: Cheryl A. Ross

Sample Results Pace Analytical Services - Greensburg PA NELAP #04222CA

(Continued)

Sample: Well 7, 1910051-019
9D30052-05 (Water) Sampled: 05/02/19 9:55 by Allan Goldberg (wecklabs)

Analyte	Result	MRL	Units	Dil	Analyzed	Qualifier
EPA 903.1						
Method: EPA 903.1	Batch ID: 342706	Prepared: 05/21/19 00:00				Analyst: MK1
Radium-226	0.342		pCi/L dry	1	05/28/19	
Uncertainty: 0.300	MDA: 0.188					
EPA 904.0						
Method: EPA 904.0	Batch ID: 342709	Prepared: 05/22/19 00:00				Analyst: JLW
Radium-228	0.592		pCi/L dry	1	05/28/19	
Uncertainty: 0.405	MDA: 0.808					



LA Testing

520 Mission Street South Pasadena, CA 91030
Phone/Fax: (323) 254-9960 / (323) 254-9982
<http://www.LATesting.com> / pasadenalab@latesting.com

LA Testing Order ID: 321910583
Customer ID: 32WECK62
Customer PO:
Project ID:

Attn: Kim Tu
Weck Laboratories, Inc.
14859 East Clark Avenue
City of Industry, CA 91745-1396

Phone: (626) 336-2139
Fax: (626) 336-2634
Received: 05/03/2019
Analyzed: 05/15/2019

Proj: 9D30052

Test Report: Determination of Asbestos Structures >10µm in Drinking Water Performed by the 100.2 Method (EPA 600/R-94/134)

ASBESTOS

Sample ID Client / EMSL	Sample Filtration Date/Time	Original Sample Vol. Filtered (ml)	Effective Filter Area (mm ²)	Area Analyzed (mm ²)	Asbestos Types	Fibers Detected	Analytical Sensitivity	Concentration		Confidence Limits
								MFL (million fibers per liter)		
9D30052-05/Well 7, 1910051-019 321910583-0001	5/3/2019 01:50 PM	30	1288	0.2210	None Detected	ND	0.19	<0.19		0.00 - 0.72
Collection Date/Time: 05/02/2019 09:55 AM										

Analyst(s)
Sherrie Ahmad (1)

Jerry Drapala Ph.D, Laboratory Manager
or Other Approved Signatory

Any questions please contact Jerry Drapala.

Initial report from: 05/15/2019 18:51:08

Sample collection and containers provided by the client. acceptable bottle blank level is defined as ≤0.01MFL>10µm. ND=None Detected. This report relates only to those items tested. This report may not be reproduced, except in full, without written permission by LA Testing. Samples received in good condition unless otherwise noted.

Samples analyzed by LA Testing South Pasadena, CA CA ELAP 2283

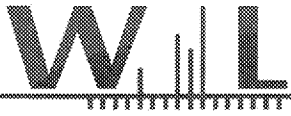

Date of Report: 19/06/04
 Laboratory Name: Weck Laboratories, Inc.
 Name of Sampler: Allan Goldberg (wecklabs)

Sample ID No.: 9D30052-05
 Signature Lab Director: *Alfred Penn*

Date/Time Sample Collected: 19/05/02 0955 Date/Time Sample Received @ Lab: 19/05/02 1115 Date Analyses Completed: 19/05/16

System Name: INGLEWOOD- CITY, WATER DEPT. System Number: 1910051

Name or Number of Sample Source: WELL #7 -

User ID: 4TH Station Number: 1910051-019
 Date/Time of Sample: | 19 | 05 | 02 | 09 | 55 Laboratory Code: 9588
 YY MM DD TT
 Date of Analyses Completed: | 19 | 05 | 16 |
 YY MM DD
 Submitted By: Weck Laboratories, Inc. Phone #: (626) 336-2139

TEST METHOD	CHEMICAL	Units	ENTRY #	ANALYSES RESULTS	MCL	DLR
E524.2	REGULATED ORGANIC CHEMICALS					
E524.2	Total Trihalomethanes (TTHMs)	ug/L	62080	ND	80	
E524.2	Bromodichloromethane	ug/L	32101	ND		1
E524.2	Bromoform	ug/L	32104	ND		1
E524.2	Chloroform (Trichloromethane)	ug/L	32106	ND		1
E524.2	Dibromochloromethane	ug/L	32105	ND		1
E524.2	Benzene	ug/L	34030	ND	1	0.5
E524.2	Carbon Tetrachloride	ug/L	32102	ND	0.5	0.5
E524.2	1,2-Dichlorobenzene (o-DCB)	ug/L	34536	ND	600	0.5
E524.2	1,4-Dichlorobenzene (p-DCB)	ug/L	34571	ND	5	0.5
E524.2	1,1-Dichloroethane (1,1-DCA)	ug/L	34496	ND	5	0.5
E524.2	1,2-Dichloroethane (1,2-DCA)	ug/L	34531	ND	0.5	0.5
E524.2	1,1-Dichloroethylene (1,1-DCE)	ug/L	34501	ND	6	0.5
E524.2	cis-1,2-Dichloroethylene (c-1,2-DCE)	ug/L	77093	ND	6	0.5
E524.2	trans-1,2-Dichloroethylene (t-1,2-DCE)	ug/L	34546	ND	10	0.5
E524.2	Dichloromethane (Methylene Chloride)	ug/L	34423	ND	5	0.5
E524.2	1,2-Dichloropropane	ug/L	34541	ND	5	0.5
E524.2	Total 1,3-Dichloropropene	ug/L	34561	ND	0.5	0.5
E524.2	Ethyl Benzene	ug/L	34371	ND	300	0.5
E524.2	Methyl tert-Butyl Ether(MTBE)	ug/L	46491	ND	13	3
E524.2	Monochlorobenzene (Chlorobenzene)	ug/L	34301	ND	70	0.5
E524.2	Styrene	ug/L	77128	ND	100	0.5
E524.2	1,1,2,2-Tetrachloroethane	ug/L	34516	ND	1	0.5
E524.2	Tetrachloroethylene (PCE)	ug/L	34475	ND	5	0.5
E524.2	Toluene	ug/L	34010	ND	150	0.5
E524.2	1,2,4-Trichlorobenzene	ug/L	34551	ND	5	0.5

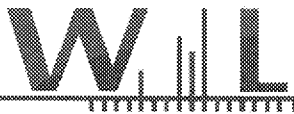

TEST METHOD	CHEMICAL	Units	ENTRY #	ANALYSES RESULTS	MCL	DLR
REGULATED ORGANIC CHEMICALS						
E524.2	1,1,1-Trichloroethane (1,1,1-TCA)	ug/L	34506	ND	200	0.5
E524.2	1,1,2-Trichloroethane (1,1,2-TCA)	ug/L	34511	ND	5	0.5
E524.2	Trichloroethylene (TCE)	ug/L	39180	ND	5	0.5
E524.2	Trichlorofluoromethane (FREON 11)	ug/L	34488	ND	150	5
E524.2	Trichlorotrifluoroethane (FREON 113)	ug/L	81611	ND	1200	10
E524.2	Vinyl Chloride (VC)	ug/L	39175	ND	0.5	0.5
E524.2	m,p-Xylene	ug/L	A-014	ND		0.5
E524.2	o-Xylene	ug/L	77135	ND		0.5
E524.2	Total Xylenes (m,p, & o)	ug/L	81551	ND	1750	
E508	Toxaphene	ug/L	39400	ND	3	1
E525.2	Molinate (ORDRAM)	ug/L	82199	ND	20	2
E525.2	Simazine (PRINCEP)	ug/L	39055	ND	4	1
E525.2	Thiobencarb (BOLERO)	ug/L	A-001	ND	70	1
E525.2	Alachlor (ALANEX)	ug/L	77825	ND	2	1
E515.4	Bentazon (BASAGRAN)	ug/L	38710	ND	18	2
E1613	2,3,7,8-TCDD (Dioxin) Units=picogram/L	pg/L	34676	ND	30	5
E515.4	2,4-D	ug/L	39730	ND	70	10
E515.4	2,4,5-TP (SILVEX)	ug/L	39045	ND	50	1
E515.4	Dalapon	ug/L	38432	ND	200	10
E515.4	Dinoseb (DNBP)	ug/L	81287	ND	7	2
E549.2	Diquat	ug/L	78885	ND	20	4
E525.2	Di(2-ethylhexyl) Adipate	ug/L	A-026	ND	400	5
E548.1	Endothall	ug/L	38926	ND	100	45
E547	Glyphosate	ug/L	79743	ND	700	25
E515.4	Pentachlorophenol (PCP)	ug/L	39032	ND	1	0.2
E515.4	Picloram	ug/L	39720	ND	500	1
UNREGULATED ORGANIC CHEMICALS						
E524.2	tert-Amyl Methyl Ether (TAME)	ug/L	A-034	ND		3
E524.2	Bromobenzene	ug/L	81555	ND		0.5
E524.2	Bromochloromethane	ug/L	A-012	ND		0.5
E524.2	Bromomethane (Methyl Bromide)	ug/L	34413	ND		0.5
E524.2	n-Butylbenzene	ug/L	A-010	ND		0.5
E524.2	sec-Butylbenzene	ug/L	77350	ND		0.5
E524.2	tert-Butylbenzene	ug/L	77353	ND		0.5
E524.2	Chloroethane	ug/L	34311	ND		0.5
E524.2	Chloromethane (Methyl Chloride)	ug/L	34418	ND		0.5
E524.2	2-Chlorotoluene	ug/L	A-008	ND		0.5
E524.2	4-Chlorotoluene	ug/L	A-009	ND		0.5
E524.2	Dibromomethane	ug/L	77596	ND		0.5
E524.2	1,3-Dichlorobenzene (m-DCB)	ug/L	34566	ND		0.5
E524.2	Dichlorodifluoromethane (Freon 12)	ug/L	34668	ND		0.5
E524.2	1,3-Dichloropropane	ug/L	77173	ND		0.5
E524.2	2,2-Dichloropropane	ug/L	77170	ND		0.5



TEST METHOD	CHEMICAL	Units	ENTRY #	ANALYSES RESULTS	MCL	DLR
UNREGULATED ORGANIC CHEMICALS						
E524.2	1,1-Dichloropropene	ug/L	77168	ND		0.5
E524.2	Diisopropyl Ether (DIPE)	ug/L	A-036	ND		3
E524.2	Ethyl tert-Butyl Ether (ETBE)	ug/L	A-033	ND		3
E524.2	Hexachlorobutadiene	ug/L	34391	ND		0.5
E524.2	Isopropylbenzene (Cumene)	ug/L	77223	ND		0.5
E524.2	p-Isopropyltoluene	ug/L	A-011	ND		
E524.2	Naphthalene	ug/L	34696	ND		0.5
E524.2	n-Propylbenzene	ug/L	77224	ND		0.5
E524.2	1,1,1,2-Tetrachloroethane	ug/L	77562	ND		0.5
E524.2	1,2,3-Trichlorobenzene	ug/L	77613	ND		0.5
SRL524	1,2,3-Trichloropropane	ug/L	77443	ND	0.005	0.005
E524.2	1,2,4-Trimethylbenzene	ug/L	77222	ND		0.5
E524.2	1,3,5-Trimethylbenzene	ug/L	77226	ND		0.5
E524.2	Methyl Ethyl Ketone (MEK, Butanone)	ug/L	81595	ND		5
E524.2	Methyl Isobutyl Ketone (MIBK)	ug/L	81596	ND		5
E525.2	Bromacil (HYVAR)	ug/L	82198	ND		10
E525.2	Butachlor	ug/L	77860	ND		0.38
E515.4	DCPA (total di & mono acid degradates)	ug/L	A-045	ND		
E525.2	Diazinon	ug/L	39570	ND		
E515.4	Dicamba (BANVEL)	ug/L	82052	ND		1.5
E525.2	Metribuzin	ug/L	81408	ND		
E525.2	Prometryn (CAPAROL)	ug/L	39057	ND		2
E525.2	Terbacil	ug/L	38882	ND		
E525.2	*** EPA Test Method 525.2 Metolachlor	ug/L	39356	ND		
E525.2	*** EPA Test Method 527 Dimethoate (CYGON)	ug/L	38458	ND		
AGRICULTURAL AND MISC ORGANIC						
E515.4	Aciflufen	ug/L	79193	ND		
E515.3	Amiben (CHLORAMBEN)	ug/L	82051	ND		
E525.2	Atrazine (AATREX)	ug/L	39033	ND	1	0.5
E525.2	Captan (Captane)	ug/L	39640	ND		0.1
E525.2	Carbophenothion (TRITHION)	ug/L	39786	ND		
E525.2	Chloroprotham (CIPC)	ug/L	81322	ND		
E525.2	Cyanazine (BLADDEX)	ug/L	81757	ND		
E515.4	2,4-DB	ug/L	38746	ND		
E515.4	Dichlorprop	ug/L	82356	ND		
E524.2	cis-1,3-Dichloropropene (D-D)	ug/L	34704	ND	0.5	
E524.2	trans-1,3-Dichloropropene	ug/L	34699	ND	0.5	
E525.2	Diphenamide (ENIDE)	ug/L	78004	ND		100
E525.2	Disulfoton	ug/L	81888	ND		
E525.2	EPTC (EPTAM)	ug/L	81894	ND		
E525.2	Prometon (PROMITOL)	ug/L	39056	ND		



TEST METHOD	CHEMICAL	Units	ENTRY #	ANALYSES RESULTS	MCL	DLR
E515.4	AGRICULTURAL AND MISC ORGANIC 2,4,5-T	ug/L	39740	ND	10	
E353.2	Total Cations & Total Anions Meq/L Value Nitrate (as N) (mg/L)	mg/L	00618	ND	10	0.4
ADDITIONAL ANALYSES						
E314	Perchlorate (ug/L)	ug/L	A-031	ND	6	4
E218.6	Chromium, hexavalent (CrVI) (ug/L)	ug/L	01032	ND		1
BNA						
E525.2	Benzo (a) Pyrene (*)	ug/L	34247	ND	0.2	0.1
E525.2	Diethylhexylphthalate (DEHP) (*)	ug/L	39100	ND	4	3
TITLE 22 CALIFORNIA CODE OF REGULATIONS - SECTION 64442 (22 CCR 64442)						
S7110C	Gross Alpha	pCi/L	01501	ND	15	3
S7110C	Gross Alpha Counting Error	pCi/L	01502	0.124		
S7110C	Gross Alpha MDA95 *	pCi/L	A-072	0.033		
E200.8	Uranium	pCi/L	28012	ND	20	1

Laboratory Comments and Description of Additional Components Found (Comments in this section are for Client Information only and will **NOT** be transmitted to CDPH via EDT):

Well 7, 1910051-019 :



Enthalpy Analytical, LLC

931 W. Barkley Ave - Orange, CA 92868
Tel: (714)771-6900 Fax: (714)538-1209
www.enthalpy.com
info-sc@enthalpy.com



Client: City of Inglewood
Address: 1 West Manchester Blvd.
Inglewood, CA 90301

Lab Request: 402874
Report Date: 06/13/2018
Date Received: 05/22/2018
Client ID: 15854

Attn: Thomas Lee

Comments: Inglewood Well 7

Sample for Herbicides and Semivolatiles could not be analyzed by the sub-lab, due to the preservation. Please see attached for all results.

This laboratory request covers the following listed samples which were analyzed for the parameters indicated on the attached Analytical Result Report. All analyses were conducted using the appropriate methods. Methods accredited by NELAC are indicated on the report. This cover letter is an integral part of the final report.

Sample # **Client Sample ID**

402874-001 Well 7-Well Blend

Thank you for the opportunity to be of service to your company. Please feel free to call if there are any questions regarding this report or if we can be of further service.

Report Review performed by: Diane Galvan, Project Manager

NOTE: Unless notified in writing, all samples will be discarded by appropriate disposal protocol 60 days from date received.

The reports of the Enthalpy Analytical, Inc. are confidential property of our clients and may not be reproduced or used for publication in part or in full without our written permission. This is for the mutual protection of the public, our clients, and ourselves.



Matrix: Drinking Water
 Sampled: 05/22/2018 15:55
 Sample #: 402874-001

Client: City of Inglewood
 Site:
 Client Sample #: Well 7-Well Blend

Collector:
 Sample Type:

Analyte	Result	DF	RDL	Units	Prepared	Analyzed By	Notes
Method: EPA 100.2	Prep Method: Method					QCBatchID:	
See Attached		1					
Method: EPA 150.1	Prep Method: Method					QCBatchID: QC1191480	
pH	7.86	1		pH Units	05/23/18 10:00	VW	T2
Method: EPA 1613B	Prep Method: See Attached					QCBatchID:	
See Attached		1					
Method: EPA 200.8	Prep Method: EPA 3010A					QCBatchID: QC1191410	
Aluminum	ND	5	250	ug/L	05/23/18	05/23/18	SBW D2
Antimony	ND	1	6	ug/L	05/23/18	05/23/18	SBW
Arsenic	ND	1	2	ug/L	05/23/18	05/23/18	SBW
Barium	83.2	1	5	ug/L	05/23/18	05/23/18	SBW
Beryllium	ND	5	5	ug/L	05/23/18	05/23/18	SBW D2
Boron	233	5	25	ug/L	05/23/18	05/23/18	SBW
Cadmium	ND	1	1	ug/L	05/23/18	05/23/18	SBW
Calcium	70200	200	20000	ug/L	05/23/18	05/23/18	SBW
Chromium	ND	5	10	ug/L	05/23/18	05/23/18	SBW D2
Copper	4.13	1	3	ug/L	05/23/18	05/23/18	SBW
Iron	375	5	125	ug/L	05/23/18	05/23/18	SBW
Lead	ND	1	5	ug/L	05/23/18	05/23/18	SBW
Magnesium	25400	20	1000	ug/L	05/23/18	05/23/18	SBW
Manganese	158	1	10	ug/L	05/23/18	05/23/18	SBW
Nickel	ND	1	5	ug/L	05/23/18	05/23/18	SBW
Selenium	2.84	1	2	ug/L	05/23/18	05/23/18	SBW
Silver	ND	1	5	ug/L	05/23/18	05/23/18	SBW
Sodium	81300	200	20000	ug/L	05/23/18	05/24/18	SBW
Thallium	ND	1	1	ug/L	05/23/18	05/23/18	SBW
Vanadium	ND	5	25	ug/L	05/23/18	05/23/18	SBW D2
Zinc	ND	1	10	ug/L	05/23/18	05/23/18	SBW
Method: EPA 200.8	Prep Method: Method					QCBatchID:	
See Attached		1					
Method: EPA 218.6	Prep Method: EPA 218.6					QCBatchID: QC1191688	
Hexavalent Chromium	ND	1	1	ug/L	05/23/18	JP	P2
Method: EPA 245.1	Prep Method: EPA 245.1					QCBatchID: QC1191601	
Mercury	ND	1	0.4	ug/L	05/29/18	05/29/18	JP
Method: EPA 300.0	Prep Method: Method					QCBatchID: QC1191464	
Chloride	106	1	1	mg/L	05/24/18	05/23/18 14:26	JP
Fluoride	0.418	1	0.2	mg/L	05/24/18	05/23/18 14:26	JP
Nitrate + Nitrite, as Nitrogen	ND	1	0.44	mg/L	05/24/18	05/23/18 14:26	JP
Nitrate, as Nitrogen	ND	1	0.1	mg/L	05/24/18	05/23/18 14:26	JP
Nitrate, as NO3	ND	1	0.44	mg/L	05/24/18	05/23/18 14:26	JP
Nitrite, as Nitrogen	ND	1	0.1	mg/L	05/24/18	05/23/18 14:26	JP
Nitrite, as NO2	ND	1	0.33	mg/L	05/24/18	05/23/18 14:26	JP
Sulfate	80.6	1	0.5	mg/L	05/24/18	05/23/18 14:26	JP
Method: EPA 314.0	Prep Method: EPA 314.0					QCBatchID: QC1191733	
Perchlorate	ND	1	4	ug/L	05/31/18	05/31/18	SBW
Method: EPA 425.1	Prep Method: Method					QCBatchID: QC1191403	
MBAS	ND	1	0.04	mg/L	05/22/18 20:00	05/22/18 21:50	NP
Method: EPA 504.1	Prep Method: Method					QCBatchID:	
See Attached		1					
Method: EPA 508	Prep Method: Method					QCBatchID:	

Matrix: Drinking Water	Client: City of Inglewood	Collector:
Sampled: 05/22/2018 15:55	Site:	
Sample #: 402874-001	Client Sample #: Well 7-Well Blend	Sample Type:

Analyte	Result	DF	RDL	Units	Prepared	Analyzed By	Notes
See Attached		1					
Method: EPA 524.2	Prep Method: 5030B					QC BatchID: QC1191405	
1,1,1,2-Tetrachloroethane	ND	1	0.5	ug/L		05/23/18	LZ
1,1,1-Trichloroethane	ND	1	0.5	ug/L		05/23/18	LZ
1,1,2,2-Tetrachloroethane	ND	1	0.5	ug/L		05/23/18	LZ
1,1,2-Trichloroethane	ND	1	0.5	ug/L		05/23/18	LZ
1,1,2-Trichlorotrifluoroethane	ND	1	10	ug/L		05/23/18	LZ
1,1-Dichloroethane	ND	1	0.5	ug/L		05/23/18	LZ
1,1-Dichloroethene	ND	1	0.5	ug/L		05/23/18	LZ
1,1-Dichloropropene	ND	1	0.5	ug/L		05/23/18	LZ
1,2,3-Trichlorobenzene	ND	1	0.5	ug/L		05/23/18	LZ
1,2,4-Trichlorobenzene	ND	1	0.5	ug/L		05/23/18	LZ
1,2,4-Trimethylbenzene	ND	1	0.5	ug/L		05/23/18	LZ
1,2-Dibromo-3-chloropropane	ND	1	0.5	ug/L		05/23/18	LZ
1,2-Dibromoethane	ND	1	0.5	ug/L		05/23/18	LZ
1,2-Dichlorobenzene	ND	1	0.5	ug/L		05/23/18	LZ
1,2-Dichloroethane	ND	1	0.5	ug/L		05/23/18	LZ
1,2-Dichloropropane	ND	1	0.5	ug/L		05/23/18	LZ
1,3,5-Trimethylbenzene	ND	1	0.5	ug/L		05/23/18	LZ
1,3-Dichlorobenzene	ND	1	0.5	ug/L		05/23/18	LZ
1,3-Dichloropropane	ND	1	0.5	ug/L		05/23/18	LZ
1,4-Dichlorobenzene	ND	1	0.5	ug/L		05/23/18	LZ
2,2-Dichloropropane	ND	1	0.5	ug/L		05/23/18	LZ
2-Chlorotoluene	ND	1	0.5	ug/L		05/23/18	LZ
4-Chlorotoluene	ND	1	0.5	ug/L		05/23/18	LZ
4-Isopropyltoluene	ND	1	0.5	ug/L		05/23/18	LZ
Benzene	ND	1	0.5	ug/L		05/23/18	LZ
Bromobenzene	ND	1	0.5	ug/L		05/23/18	LZ
Bromochloromethane	ND	1	0.5	ug/L		05/23/18	LZ
Bromodichloromethane	ND	1	0.5	ug/L		05/23/18	LZ
Bromoform	ND	1	0.5	ug/L		05/23/18	LZ
Bromomethane	ND	1	0.5	ug/L		05/23/18	LZ
Carbon Tetrachloride	ND	1	0.5	ug/L		05/23/18	LZ
Chlorobenzene	ND	1	0.5	ug/L		05/23/18	LZ
Chlorodibromomethane	ND	1	0.5	ug/L		05/23/18	LZ
Chloroethane	ND	1	0.5	ug/L		05/23/18	LZ
Chloroform	ND	1	0.5	ug/L		05/23/18	LZ
Chloromethane	ND	1	0.5	ug/L		05/23/18	LZ
cis-1,2-Dichloroethene	ND	1	0.5	ug/L		05/23/18	LZ
cis-1,3-dichloropropene	ND	1	0.5	ug/L		05/23/18	LZ
Dibromomethane	ND	1	0.5	ug/L		05/23/18	LZ
Dichlorodifluoromethane	ND	1	0.5	ug/L		05/23/18	LZ
Ethylbenzene	ND	1	0.5	ug/L		05/23/18	LZ
Hexachlorobutadiene	ND	1	0.5	ug/L		05/23/18	LZ
Isopropylbenzene	ND	1	0.5	ug/L		05/23/18	LZ
m and p-Xylene	ND	1	0.5	ug/L		05/23/18	LZ
Methylene chloride	ND	1	0.5	ug/L		05/23/18	LZ
Methyl-t-butyl Ether (MTBE)	ND	1	3	ug/L		05/23/18	LZ
Naphthalene	ND	1	0.5	ug/L		05/23/18	LZ
N-butylbenzene	ND	1	0.5	ug/L		05/23/18	LZ
N-propylbenzene	ND	1	0.5	ug/L		05/23/18	LZ
o-Xylene	ND	1	0.5	ug/L		05/23/18	LZ

Matrix: Drinking Water
 Sampled: 05/22/2018 15:55
 Sample #: 402874-001

Client: City of Inglewood
 Site:
 Client Sample #: Well 7-Well Blend

Collector:
 Sample Type:

Analyte	Result	DF	RDL	Units	Prepared	Analyzed By	Notes
Sec-butylbenzene	ND	1	0.5	ug/L	05/23/18	LZ	
Styrene	ND	1	0.5	ug/L	05/23/18	LZ	
Tert-butylbenzene	ND	1	0.5	ug/L	05/23/18	LZ	
Tetrachloroethene	ND	1	0.5	ug/L	05/23/18	LZ	
Toluene	ND	1	0.5	ug/L	05/23/18	LZ	
trans-1,2-dichloroethene	ND	1	0.5	ug/L	05/23/18	LZ	
trans-1,3-dichloropropene	ND	1	0.5	ug/L	05/23/18	LZ	
Trichloroethene	ND	1	0.5	ug/L	05/23/18	LZ	
Trichlorofluoromethane	ND	1	5	ug/L	05/23/18	LZ	
Vinyl Chloride	ND	1	0.5	ug/L	05/23/18	LZ	
Xylenes (Total)	ND	1	0.5	ug/L	05/23/18	LZ	
<u>Surrogate</u>		<u>% Recovery</u>	<u>Limits</u>	<u>Notes</u>			
1,2-Dichloroethane-d4 (SUR)		98	70-145				
4-Bromofluorobenzene (SUR)		109	70-145				
Dibromofluoromethane (SUR)		102	70-145				
Toluene-d8 (SUR)		100	70-145				
Method: EPA 531.1	Prep Method: Method					QCBatchID:	
See Attached		1					
Method: EPA 547	Prep Method: Method					QCBatchID:	
Glyphosate	See Attached	1					
Method: EPA 548.1	Prep Method: Method					QCBatchID:	
Endothall	See Attached	1					
Method: EPA 549.2	Prep Method: Method					QCBatchID:	
See Attached		1					
Method: EPA 900.0	Prep Method: Method					QCBatchID:	
See Attached		1					
Method: SM 2120-B	Prep Method: Method					QCBatchID: QC1191475	
Color	ND	1	5	Color Unit	05/23/18 10:00	WW	
Method: SM 2130-B	Prep Method: Method					QCBatchID: QC1191479	
Turbidity	0.75	1	0.1	NTU	05/23/18 10:00	WW	
Method: SM 2150-B	Prep Method: Method					QCBatchID: QC1191476	
Odor Threshold	ND	1	1	T.O.N	05/23/18 10:00	WW	
Method: SM 2320-B	Prep Method: Method					QCBatchID: QC1191732	
Bicarbonate (HCO3)	310	2.5	12.5	mg/L	05/31/18	WW	
Carbonate (CO3)	ND	2.5	12.5	mg/L	05/31/18	WW	
Hydroxide (OH)	ND	2.5	12.5	mg/L	05/31/18	WW	
Total Alkalinity (as CaCO3)	260	2.5	12.5	mg/L	05/31/18	WW	
Method: SM 2340-B	Prep Method: None					QCBatchID: QC1191410	
Total Hardness	278	1	0.5	mg/L	05/23/18		
Method: SM 2510-B	Prep Method: Method					QCBatchID: QC1191841	
Specific Conductance	970	1	1	umhos/cm	05/29/18	TD	
Method: SM 2540-C	Prep Method: SM 2540-C					QCBatchID: QC1191661	
Total Dissolved Solids	512	2	20	mg/L	05/29/18	05/29/18	TD
Method: SM 4500-CN-E	Prep Method: Method					QCBatchID: QC1191459	
Cyanide	ND	1	0.01	mg/L	05/23/18	05/23/18	TP
Method: SM 4500-SiO2-C	Prep Method: Method					QCBatchID: QC1191443	
Silica	35	5	5	mg/L	05/23/18	05/23/18	TP



WECK LABORATORIES, INC.

Certificate of Analysis

FINAL REPORT

Work Orders: 9E02018

Report Date: 5/15/2019

Project: Well# 7

Received Date: 5/2/2019

Turnaround Time: Normal

Phones: (310) 412-8890

Fax: (310) 330-5798

Attn: Ismael Perez

P.O. #:

Client: City of Inglewood
359 North Eucalyptus Avenue
Inglewood, CA 90302

Billing Code:

Dear Ismael Perez :

Enclosed are the results of analyses for samples received 5/2/2019 with the Chain-of-Custody document. The samples were received in good condition, at 5.9 °C and on ice. All analysis met the method criteria except as noted in the case narrative or in the report with data qualifiers.

Sample Results

Sample: Well #7 Sampled: 05/02/19 10:15 by Allan Goldberg (wecklabs)

9E02018-01 (Water)

Analyte	Result	MRL	Units	DI	Analyzed	Qualifier
Method: SM 92158	Instr: _ANALYST	Prepared: 05/02/19 13:53			Analyst: jns	
Heterotrophic Plate Count	ND	1.0	CFU/ml	1	05/04/19 11:40	

Sample: Well #7 Sampled: 05/02/19 9:55 by Allan Goldberg (wecklabs)

9E02018-02 (Water)

Analyte	Result	MRL	Units	DI	Analyzed	Qualifier
Method: SM 92238	Instr: _ANALYST	Prepared: 05/02/19 13:53			Analyst: slh	
E. coli	Absent	1.0	N/A	1	05/03/19 10:36	
Total Coliform	Absent	1.0	N/A	1	05/03/19 10:36	

APPENDIX 4

Vulnerability Assessment and Monitoring Frequency Guidelines LGLE

STATE WATER RESOURCES CONTROL BOARD, DIVISION OF DRINKING WATER (DDW)

Vulnerability Assessment and Monitoring Frequency Guidelines

Source Class Code: LGLE, Community Water System, Groundwater, Population > 3300

Monitoring Period: January 1, 2017 to December 31, 2019

INORGANIC CHEMICALS Table 64431-A	MCL (mg/L)	Vulnerability	Monitoring Frequency
Aluminum (See Also Secondary Standards)	1.	N/A	Every Three Years
Antimony	0.006	N/A	Every Three Years
Arsenic	0.010	N/A	Every Three Years
Asbestos	7 MFL*	Non-Vulnerable	Waived
		Vulnerable	Once during this period if your source(s) is listed in the Asbestos Table ¹
Barium	1.	N/A	Every Three Years
Beryllium	0.004	N/A	Every Three Years
Cadmium	0.005	N/A	Every Three Years
Chromium	0.05	N/A	Every Three Years
Cyanide	0.15	Vulnerable	Every Three Years
Fluoride	2.0	N/A	Every Three Years
Hexavalent Chromium	0.010	N/A	Every Three Years
Mercury	0.002	N/A	Every Three Years
Nickel	0.1	N/A	Every Three Years
Nitrate (as Nitrogen)	10.	N/A	Annually if < 1/2 MCL Quarterly if ≥ 1/2 MCL but ≤ MCL
Nitrite (as Nitrogen)	1.0	N/A	Every Three Years if < 1/2 MCL Quarterly if ≥ 1/2 MCL but ≤ MCL
Perchlorate	0.006	N/A	Every Three Years Annually if your source(s) is listed in the Perchlorate Table ² Quarterly if ≥ DLR but ≤ MCL
Selenium	0.05	N/A	Every Three Years
Thallium	0.002	N/A	Every Three Years

*MFL - Million fibers per liter; MCL for fibers exceeding 10 um in length

¹DDW has determined certain sources to be vulnerable to asbestos contamination due to a review of USGS information. The enclosed Asbestos Table indicates which source is vulnerable to asbestos. You do not need to conduct monitoring if an Asbestos Table is not enclosed.

²DDW requires some sources to have annual perchlorate monitoring due to known contamination. The enclosed Perchlorate Table indicates which source needs annual perchlorate monitoring. You do not need to conduct annual monitoring if a Perchlorate Table is not enclosed.

³If you submitted a waiver request for Thiobencarb, please refer to the enclosed Thiobencarb Table for monitoring requirements.

GENERAL MINERAL Section 64449 (b)(2)	MCL (mg/L)	Vulnerability	Monitoring Frequency
Bicarbonate Alkalinity ✓	---	N/A	Every Three Years
Calcium ✓	---	N/A	Every Three Years
Carbonate Alkalinity	---	N/A	Every Three Years
Hydroxide Alkalinity	---	N/A	Every Three Years
Magnesium	---	N/A	Every Three Years
Sodium	---	N/A	Every Three Years
Total Hardness	---	N/A	Every Three Years
pH	---	N/A	Every Three Years
SECONDARY STANDARDS Tables 64449-A	MCL (mg/L)	Vulnerability	Monitoring Frequency
Aluminum	0.2 mg/L	N/A	Every Three Years
Color	15 Units	N/A	Every Three Years
Copper	1.0 mg/L	N/A	Every Three Years
Foaming Agents (MBAS)	0.5 mg/L	N/A	Every Three Years
Iron	0.3 mg/L	N/A	Every Three Years
Manganese	0.05 mg/L	N/A	Every Three Years
Odor - Threshold	3 Units	N/A	Every Three Years
Silver	0.1 mg/L	N/A	Every Three Years
Thiobencarb	0.001 mg/L	N/A	Follow monitoring requirement in Table 64444-A Part (b)
Turbidity	5 NTU	N/A	Every Three Years
Zinc	5.0 mg/L	N/A	Every Three Years
Methyl- <i>tert</i> -butyl ether (MTBE) ✓	0.005 mg/L	N/A	Follow monitoring requirement in Table 64444-A Part (a)
SECONDARY STANDARDS Tables 64449-B	MCL (mg/L)	Vulnerability	Monitoring Frequency
Total Dissolved Solids (TDS)	500-1000 mg/L	N/A	Every Three Years
Specific Conductance	900 - 1600 umhos	N/A	Every Three Years
Chloride	250-500 mg/L	N/A	Every Three Years
Sulfate	250-500 mg/L	N/A	Every Three Years
RADIONUCLIDES Sections 64442 and 64443	MCL (pCi/L)	Vulnerability	Monitoring Frequency
Gross Alpha Particle Activity	15	At a minimum all regulated isotopes must be monitored at least once per 9-year cycle. Based on your last round of monitoring results	
Combined Radium-226 and Radium-228	5		
Uranium	20		
Tritium	20,000	Non-Vulnerable, unless notified by DDW	Waived, unless notified by DDW
Strontium	8		
Beta/photon emitters	4 millirem/year		

VOLATILE ORGANIC CHEMICALS (VOCs) Table 64444-A Part (a)	MCL (mg/L)	Vulnerability	Monitoring Frequency
Benzene	0.001	Vulnerable	Annually Quarterly if \geq DLR but \leq MCL Monthly if $>$ MCL
Carbon Tetrachloride	0.0005	Vulnerable	As Above
1,2-Dichlorobenzene	0.6	Vulnerable	As Above
1,4-Dichlorobenzene	0.005	Vulnerable	As Above
1,1-Dichloroethane	0.005	Vulnerable	As Above
1,2-Dichloroethane	0.0005	Vulnerable	As Above
1,1-Dichloroethylene	0.006	Vulnerable	As Above
cis-1,2-Dichloroethylene	0.006	Vulnerable	As Above
trans-1,2-Dichloroethylene	0.01	Vulnerable	As Above
Dichloromethane	0.005	Vulnerable	As Above
1,2-Dichloropropane	0.005	Vulnerable	As Above
1,3-Dichloropropane	0.0005	Vulnerable	As Above
Ethylbenzene	0.3	Vulnerable	As Above
Methyl- <i>tert</i> -butyl ether (MTBE)	0.013	Vulnerable	As Above
Monochlorobenzene	0.07	Vulnerable	As Above
Styrene	0.1	Vulnerable	As Above
1,1,2,2-Tetrachloroethane	0.001	Vulnerable	As Above
Tetrachloroethylene	0.005	Vulnerable	As Above
Toluene	0.15	Vulnerable	As Above
1,2,4-Trichlorobenzene	0.005	Vulnerable	As Above
1,1,1-Trichloroethane	0.200	Vulnerable	As Above
1,1,2-Trichloroethane	0.005	Vulnerable	As Above
Trichlorofluoromethane	0.15	Vulnerable	As Above
1,1,2-Trichloro-1,2,2-trifluoroethane	1.2	Vulnerable	As Above
Trichloroethylene	0.005	Vulnerable	As Above
Vinyl Chloride	0.0005	Vulnerable	As Above
Xylenes	1.750	Vulnerable	As Above

SYNTHETIC ORGANIC CHEMICALS (SOCs) Table 64444-A Part (b)	MCL (mg/L)	Vulnerability	Monitoring Frequency
Alachlor	0.002	Vulnerable	Two quarterly samples in one year during this period
Atrazine	0.001	Vulnerable	Two quarterly samples in one year during this period
Bentazon	0.018	Vulnerable	Two quarterly samples in one year during this period
Benzo (a) pyrene	0.0002	Non-Vulnerable	Waived
Carbofuran	0.018	Non-Vulnerable	Waived
Chlordane	0.0001	Non-Vulnerable	Waived
2,4-D	0.07	Vulnerable	Two quarterly samples in one year during this period
Dalapon	0.2	Non-Vulnerable	Waived
1,2-Dibromo-3-chloropropane (DBCP)	0.0002	Non-Vulnerable	Waived
Di (2-ethylhexyl) adipate	0.4	Non-Vulnerable	Waived
Di (2-ethylhexyl) phthalate (DEHP)	0.004	Vulnerable	Two quarterly samples in one year during this period
Dinoseb	0.007	Vulnerable	Two quarterly samples in one year during this period
Diquat	0.02	Vulnerable	Two quarterly samples in one year during this period
Endothall	0.1	Vulnerable	Two quarterly samples in one year during this period
Endrin	0.002	Non-Vulnerable	Waived
Ethylene Dibromide (EDB)	0.00005	Non-Vulnerable	Waived
Glyphosate	0.7	Vulnerable	Two quarterly samples in one year during this period
Heptachlor	0.00001	Non-Vulnerable	Waived
Heptachlor Epoxide	0.00001	Non-Vulnerable	Waived
Hexachlorobenzene	0.001	Non-Vulnerable	Waived
Hexachlorocyclopentadiene	0.05	Non-Vulnerable	Waived
Lindane	0.0002	Non-Vulnerable	Waived
Methoxychlor	0.03	Non-Vulnerable	Waived
Molinate	0.02	Non-Vulnerable	Waived
Oxamyl (Vydate)	0.05	Non-Vulnerable	Waived
Pentachlorophenol	0.001	Vulnerable	Two quarterly samples in one year during this period
Picloram	0.5	Non-Vulnerable	Waived
Polychlorinated Biphenyls (PCBs)	0.0005	Non-Vulnerable	Waived
Simazine	0.004	Vulnerable	Two quarterly samples in one year during this period
Thiobencarb	0.07	Refer to "Thiobencarb Table" ³	Vulnerable-Two quarterly samples in one year during this period Waived-No Samples required in this period
Toxaphene	0.003	Vulnerable	Two quarterly samples in one year during this period
2,3,7,8-TCDD (Dioxin)	3x10 ⁻⁸	Non-Vulnerable	Waived
2,4,5-TP (Silvex)	0.05	Non-Vulnerable	Waived

APPENDIX 5

Treatment Facility Classification Worksheet

Treatment Classification

City of Inglewood - System 1910051

Treatment Facility: Sanford M. Anderson Water Treatment Plant (Wells 1, 2, 4, 6, and 7)

Date: 9/13/18

Section 64413.1 Classification of Water Treatment Facilities Table 64413.1-A Water Treatment Facility Class Designation

Total Points	Class	Designation
Less than 20	T1	
20 through 39	T2	X
40 through 59	T3	
60 through 79	T4	
80 or more	T5	

Section 64413.1(b). The calculation of total points for each water treatment facility shall be the sum of the points derived in each of paragraphs (1) through (13) except where a treatment facility treats more than one source, in which case the source with the highest average of each contaminant shall be used to determine the point value in paragraphs (2) through (6).

Section 63750.85. "Water treatment facility" means a group or assemblage of structures, equipment, and processes that treat or condition a water supply, affecting the physical, chemical, or bacteriological quality of water distributed or otherwise offered to the public for domestic use by a public water system as defined in Health and Safety Code Section 116275. **Facilities consisting of only disinfection for which no *Giardia* or virus reduction is required pursuant to Section 64654(a) and which are under the control of a certified distribution operator are not included as water treatment facilities.**

INSTRUCTIONS: For each paragraph item that applies to the system, insert the appropriate number of points in the **Points Assigned** column. For paragraphs (1), (2), (3), (7), (8), (9), (12), and (13), assign **one value only** (whichever is highest) for each paragraph. For paragraphs (4), (5), (6), (10), and (11), assign **all point values** that apply for each paragraph. This spreadsheet will total the points and determine the system's classification.

Paragraph	Points Possible	Points Assigned
(1) Source Water Used by Facility		
Groundwater and/or purchased treated water meeting primary and secondary drinking water standards, as defined in Section 116275 of the HSC	2	2
Water that includes any surface water or groundwater under the direct influence of surface water	5	
(2) Influent Water Microbiological Quality, Median Coliform Density, Most Probable Number Index (MPN) (a)		N/A
Less than 1 per 100 mL	0	
1 through 100 per 100 mL	2	
Greater than 100 through 1,000 per 100 mL	4	
Greater than 1,000 through 10,000 per 100 mL	6	
Greater than 10,000 per 100 mL	8	
(3) Influent Water Turbidity, Maximum Influent Turbidity Level, Nephelometric Turbidity Units (NTU) (b)		N/A
Less than 15	0	
15 through 100	2	
Greater than 100	5	
(4) Influent Water Perchlorate, Nitrate, and Nitrite; Perchlorate, Nitrate, and Nitrite Data Average (c)		
Less than or equal to the MCL	0	0
Greater than the MCL	5	
(5) Influent Water Chemical and Radiological Contamination, Contaminant Data Average (d)		
Less than or equal to the MCL	0	0
Greater than the MCL	2	
5 times the MCL or greater	5	

City of Inglewood - System 1910051

(6) Surface Water Filtration Treatment		N/A
Conventional, direct, or inline	15	
Diatomaceous earth	12	
Slow sand, membrane, cartridge, or bag filter	8	
Backwash recycled as part of process	5	
(7) The points for each treatment process utilized by the facility and not included in paragraph (6) that is used to reduce the concentration of one or more contaminants for which a primary MCL exists, pursuant to Table 64431-A, Table 64444-A, and Tables 64442 and 64443, shall be 10. Blending shall only be counted as a treatment process if one of the blended sources exceeds a primary MCL.	10	0
(8) The points for each treatment process not included in paragraphs (6) or (7) that is used to reduce the concentration of one or more contaminants for which a secondary MCL exists, pursuant to Tables 64449-A and 64449-B, shall be 3. Blending shall only be counted as a treatment process if one of the blended sources exceeds a secondary MCL.	3	3
(9) The points for each treatment process not included in paragraphs (6), (7), or (8) that is used for corrosion control or fluoridation shall be 3.	3	0
(10) Disinfection Treatment		N/A
Ozone	10	
Chlorine and/or chloramine	10	
Chlorine dioxide	10	
Ultraviolet (UV)	7	
(11) Disinfection/Oxidation Treatment without Inactivation Credit		
Ozone	5	
Chlorine and/or chloramine	5	
Chlorine dioxide	5	5
Ultraviolet (UV)	3	
Other oxidants	5	
(12) The points for any other treatment process that alters the physical or chemical characteristics of the drinking water and that was not included in paragraphs (6), (7), (8), (9), (10), or (11) shall be 3.	3	0
(13) The points for facility flow shall be 2 per million gallons per day or fraction thereof of maximum permitted treatment facility capacity, up to a maximum of 50 points; except that for facilities utilizing only blending, the points shall be based on the flow from the contaminated source and the dilution flow required to meet the MCL(s) specified in Tables 64431-A, 64444-A, 64449-A, 64449-B, 64442, and 64443.	50 max 8.64 MGD	17.3
Total Points		27.3

Item #8 - treatment for manganese and iron

Item #13 - Capacity of Sanford TP is 8.64MGD

(a) Median of all total coliform analyses completed in the previous 24 months.

(b) For facilities treating surface water or groundwater under the direct influence of surface water, based on the previous 24 months of data, except that if turbidity data is missing for one or more of the months, the points given for turbidity shall be 5. The maximum influent turbidity sustained for at least one hour according to an on-line turbidimeter shall be used unless such data is not available, in which case, the maximum influent turbidity identified by grab sample shall be used. For facilities that have not been in operation for 24 months, the available data shall be used. For facilities whose permit specifies measures to ensure that influent turbidity will not exceed a specified level, the points corresponding to that level shall be assigned.

(c) The points for influent water perchlorate, nitrate, or nitrite levels shall be determined by an average of the three most recent sample results. The points assigned should be the sum of the points for each contaminant.

(d) The points for other influent water contaminants with primary MCLs shall be a sum of the points for each of the inorganic contaminants (Table 64431-A), organic contaminants (Table 64444-A) and radionuclides (Tables 64442 and 64443). The points for each contaminant shall be based on an average of the three most recent sample results. If monitoring for a contaminant has been waived pursuant to Sections 64432(k), 64432.2(c) or 64445(d), the points shall be zero for that contaminant.