

LEGEND

- MU2C LIMIT OF WORK
- - - DRAINAGE AREA OUTLINE
- [Pattern] RDA-1 FIRST LEVEL LID PLAN
- [Pattern] RDA-13 ROOF DRAINAGE AREA. SEE SHEET C3.04
- [Pattern] P1 BIO-FILTRATION PLANTERS
- [Pattern] F1 FILTERRA BIOFILTRATION SYSTEM

CONSTRUCTION NOTES:

1. STORMWATER PLANTER CONSTRUCTED PER LA COUNTY LID STANDARDS MANUAL. REFER TO DETAIL X, SHEET CXXX.
2. FILTERRA BIOFILTRATION SYSTEM. REFER TO DETAIL X, SHEET CXXX.

NOTE

1. LID PLANTERS AT PODIUM LEVEL ARE TO DISCHARGE INTO SEPARATE PLUMBING SYSTEM.

MU-10
(PER SEPARATE PLAN)

DISTRICT DRIVE

NORTH PRIVATE ROAD-O

SOUTH PRIVATE ROAD-O

RETAIL
(NOT A PART)

**COMPLETE DRAWINGS
WILL BE SUBMITTED WITH
BUILDING PLAN CHECK.
FOR REFERENCE ONLY.**

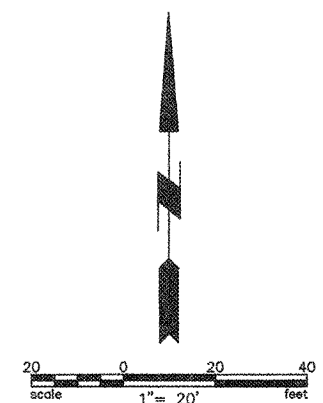

LOS ANGELES | IRVINE | OAKLAND
This document is the property of T&A Architects, Inc. ©2017. All rights reserved. No part of this document may be reproduced or transmitted in any form or by any means electronic or mechanical, including photocopying and recording, or by any information storage or retrieval system, without the prior written permission of T&A Architects, Inc.

WILSON
MEANY



D & D ENGINEERING, INC.
801 S. LA CIBOLA BLVD., SUITE 106
HOLLYWOOD, CA 91601
Phone: 323-335-4122

HOLLYWOOD PARK RESIDENTIAL - MU-2C
INGLEWOOD, CALIFORNIA
HOLLYWOOD PARK RETAIL AND
COMMERCIAL INVESTORS, LLC

FIRST LEVEL LOW IMPACT
DEVELOPMENT (LID) PLAN
NOT FOR CONSTRUCTION

THIS SET OF CONSTRUCTION
DOCUMENTS HAS BEEN
PREPARED FOR THE
CONSTRUCTION OF AN
APARTMENT PROJECT

C3.03

2017-083-01
FOR REVIEW
1" = 20'
SCALE
PLOT PLAN
RESUBMITTAL
ISSUED AT
09-21-2018
DATE