

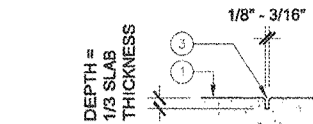

A: SAWCUT JOINT

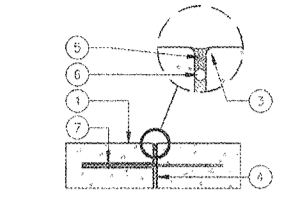

B: TOOLED JOINT



C: EXPANSION JOINT

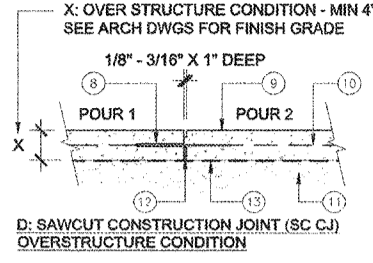

D: SAWCUT CONSTRUCTION JOINT (SC CJ) OVERSTRUCTURE CONDITION

LEGEND

- PAVING FINISH SURFACE
- SAWCUT
- 1/4" R @ EDGES TYP.
- PREMOLDED EJ FILLER
- JOINT SEALANT/CAULK, COLOR TO BE SELECTED BY LANDSCAPE ARCHITECT. SUBMIT COLOR SAMPLES PRIOR TO INSTALLATION.
- BACKER ROD
- 18" #4 REBAR W/ SPEED DOWEL @ 36" OC, CENTER IN CONC. AT COLD JOINTS & EJS
- #4 REBAR DOWEL 18" LONG @ 24 O.C. W/ SPEED DOWEL SLEEVE
- CAST-IN-PLACE CONCRETE - SEE PLANS FOR COLOR AND FINISH
- #4 REBAR @ 18" O.C. EACH WAY, PLACE IN MIDDLE OF SLAB, TYP.
- STRUCTURAL SLAB, SEE STRUCTURAL PLANS
- 1/4" FOAM JOINT FILLER
- WATERPROOFING/DRAINAGE LAYER, SEE ARCH PLANS

**12 CONCRETE JOINTS**

SCALE: NTS

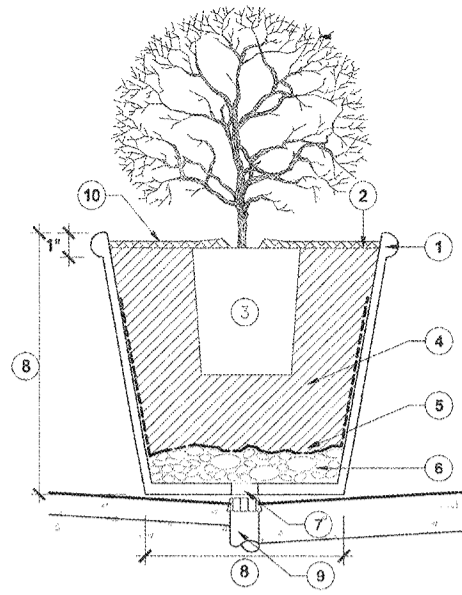

LEGEND

- POT, WATERPROOF PRIOR TO BACKFILLING.
- FINISH GRADE.
- ROOTBALL.
- BACKFILL MIX.
- SOIL SEPARATOR CLOTH, ADHERE TO SIDES OF POT (PRIOR TO BACKFILLING) WITH SILICON SEAL.
- 3" LAYER DRAINAGE ROCK, PER SPECIFICATIONS
- DRAIN HOLES CENTERED OVER SLAB DRAIN
- SEE PLAN FOR POT HEIGHT AND DIAMETER.
- DRAIN, SEE PLUMBING PLAN
- 3" THICK LAYER OF MULCH, 1"-2" MEXICAN BEACH BLACK PEBBLES, AVAILABLE AT SWB (877) 792.7625

**9 PLANTING POT DETAIL**

SCALE: NTS

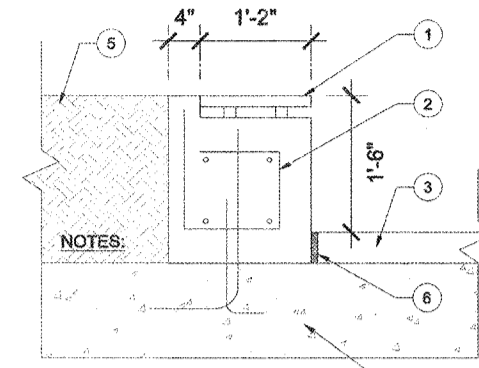

- IPE BENCH, ADVANTAGE LUMBER
- RIB BAR
- ADJACENT TILE
- STRUCTURE SLAB
- ARTIFICIAL GRASS
- EXPANSION JOINT

**6 C.I.P. CONCRETE SEATING WALL WITH IPE BENCH**

SCALE: NTS

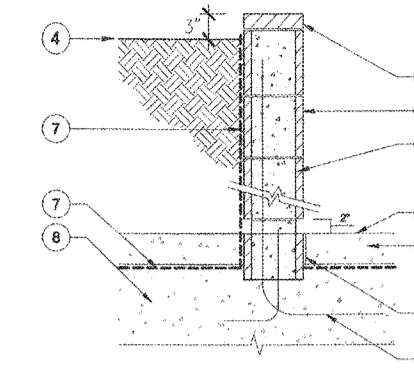

LEGEND

- CMU WALL, SEE ARCH DWGS
- STUCCO
- CMU PRECISION CAP
- FINISH GRADE, SEE ARCH DWGS
- EXPANSION JOINT
- CONCRETE SLAB ADJACENT, SEE ARCH DWGS
- WATERPROOFING, SEE ARCH DWGS
- STRUCTURAL SLAB
- DOWEL AND REINFORCEMENT AS REQUIRED, SEE STRUCTURAL DWGS

**3 FREESTANDING CMU WALL ON STRUCTURE**

SCALE: NTS

- PRECAST CONCRETE PAVER. SEE PAVING SCHEDULE.
- 8"x2" MORTARLESS PLASTIC SPACER AT EACH PAVER CORNER, AVAILABLE THRU STEPSTONE, INC. (310.327.7474) OR APPROVED EQUAL. INSTALL PER MANUFACTURERS RECOMMENDATIONS.
- 1/4" WASHED CRUSHED AGGREGATE BASE, CONSOLIDATE IN PLACE WITH VIBRATORY EQUIPMENT
- 1/4" MAX. GRAVEL FILLED JOINT
- VERTICAL SURFACE, TYP.
- STRUCTURAL SLAB PER STRUCTURAL ENGINEER
- WATERPROOFING PER WATERPROOFING CONSULTANT
- FINISH SURFACE

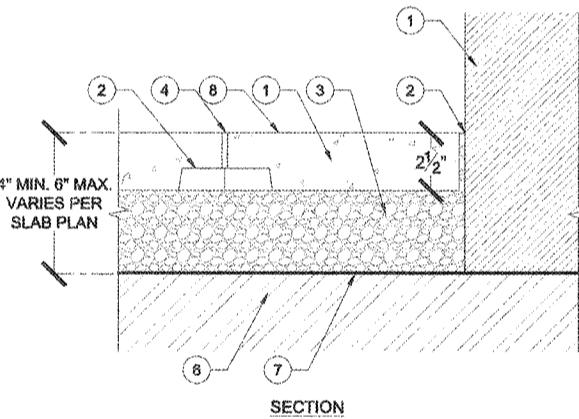

NOTES:  
FIELD PATTERN SHALL BE SET PER CONSTRUCTION PLAN LAYOUT

**11 CONCRETE PAVER ON AGGREGATE BASE**

SCALE: NTS

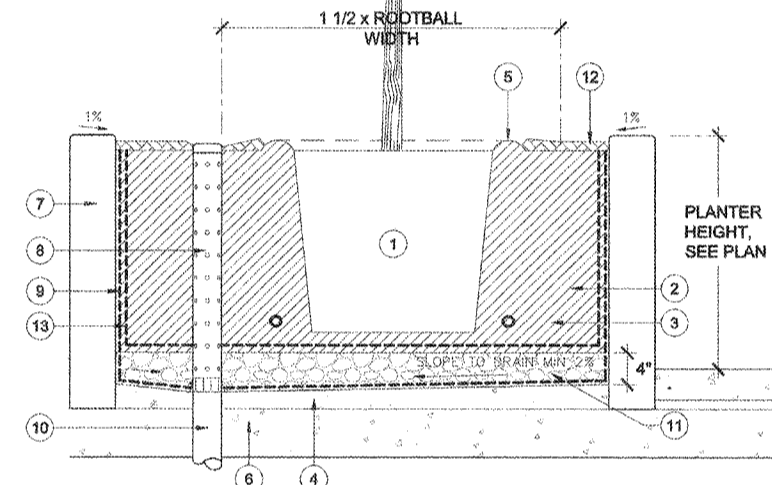

LEGEND

- ROOTBALL
- PLANTING SOIL, SEE SPECIFICATIONS
- PLANT FERTILIZER TABLETS, SEE SPECIFICATIONS.
- TOPPING SLAB, SEE ARCH DWGS
- WATERING BASIN
- STRUCTURAL SLAB, SEE STRUCTURE DWGS.
- PLANTER WALL, SEE ARCH DWGS.
- PLANTER DRAIN ASSEMBLY: 4" DIA. PERFORATED P.V.C. RIGID DRAINAGE
- PIPE WRAPPED IN DRAINAGE SOCK WITH REMOVABLE THREADED P.V.C. CAP WITH (3) 1/4" HOLES DRILLED THROUGH, SEE SPECIFICATION
- WATER PROOFING, SEE ARCH PLAN.
- PLANTER DRAINAGE, SEE PLUMBING PLAN.
- 3/8" CRUSHED ROCK, SEE SPECIFICATION
- 3" THICK LAYER OF MULCH, SEE SPECS
- FILTER FABRIC

**8 TREE OVER STRUCTURE**

SCALE: NTS

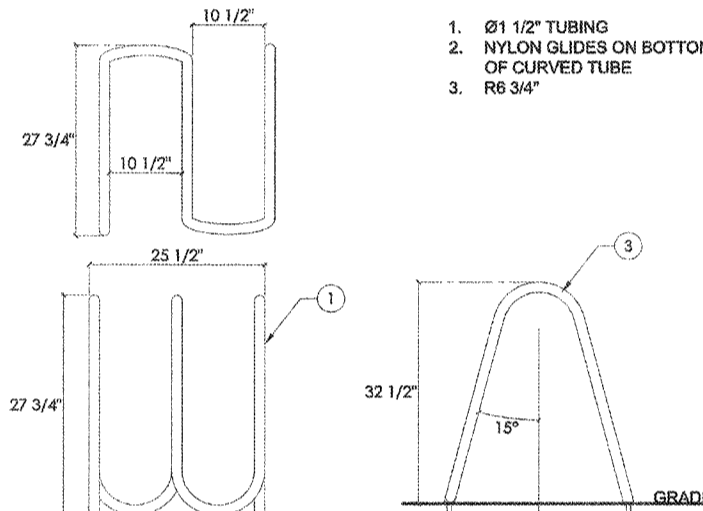

- Ø1 1/2" TUBING
- NYLON GLIDES ON BOTTOM OF CURVED TUBE
- R6 3/4"

NOTE:  
5/8-11 UNC X 4' LONG THREADED RODS WITH THREAD PATCH INCLUDED. REFER TO INSTALLATION GUIDE FOR MORE DETAILS.  
CONFIDENTIAL DRAWING INFORMATION CONTAINED HEREIN IS THE PROPERTY OF LANDSCAPE FORMS, INC.  
INTENDED USE IS LIMITED TO DESIGN PROFESSIONALS SPECIFYING LANDSCAPE FORMS, INC. PRODUCTS AND THEIR DIRECT CLIENTS. DRAWING IS NOT TO BE COPIED OR DISCLOSED TO OTHERS WITHOUT THE CONSENT OF LANDSCAPE FORMS, INC.  
© 2013 LANDSCAPE FORMS, INC. ALL RIGHTS RESERVED.

**5 BIKE RACK DETAIL**

SCALE: NTS

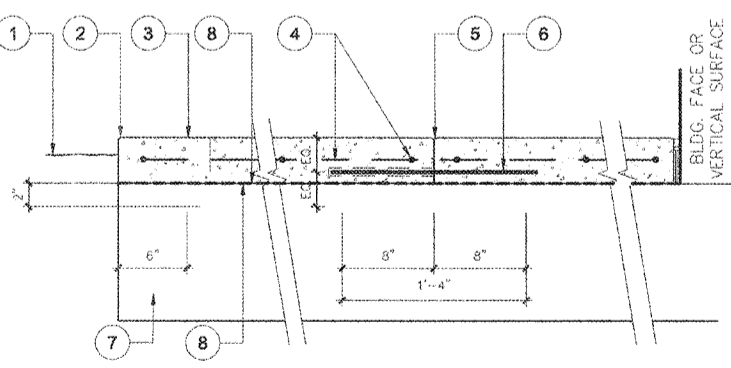

LEGEND

- FINISH GRADE
- 1/4" RAD. AT ALL EXPOSED EDGES
- NOMINAL 3" THICK CONCRETE PAVING - FINISH / COLOR PER PLAN
- #3 REBAR @ 18" O.C. BOTH WAYS, 3,000 PSI
- COLD JOINT / E.J. - SEE JOINTS DETAIL
- DOWEL - SEE JOINTS DETAIL
- EXISTING STRUCTURAL SLAB
- WATER PROOFING BY GENERAL CONTRACTOR, PER SEPERATE SUBMITTAL

**10 CONCRETE PAVING**

SCALE: NTS

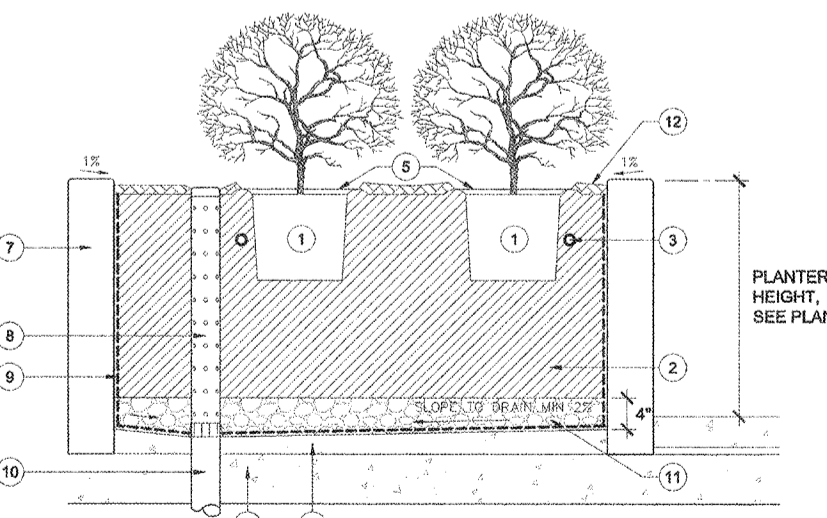

LEGEND

- ROOTBALL
- PLANTING SOIL, SEE SPECIFICATIONS
- PLANT FERTILIZER TABLETS, SEE SPECIFICATIONS.
- TOPPING SLAB, SEE ARCH DWGS
- WATERING BASIN
- STRUCTURAL SLAB, SEE STRUCTURE DWGS
- PLANTER WALL, SEE ARCH DWGS
- PLANTER DRAIN ASSEMBLY: 4" DIA. PERFORATED P.V.C. RIGID DRAINAGE PIPE WRAPPED IN DRAINAGE SOCK WITH
- REMOVABLE THREADED P.V.C. CAP WITH (3) 1/4" HOLES DRILLED THROUGH, SEE SPECIFICATION
- WATER PROOFING, SEE ARCH PLAN.
- PLANTER DRAINAGE, SEE PLUMBING PLAN.
- 3/8" CRUSHED ROCK, SEE SPECIFICATION
- 3" THICK LAYER OF MULCH

**7 SHRUB PLANTING OVER STRUCTURE**

SCALE: NTS

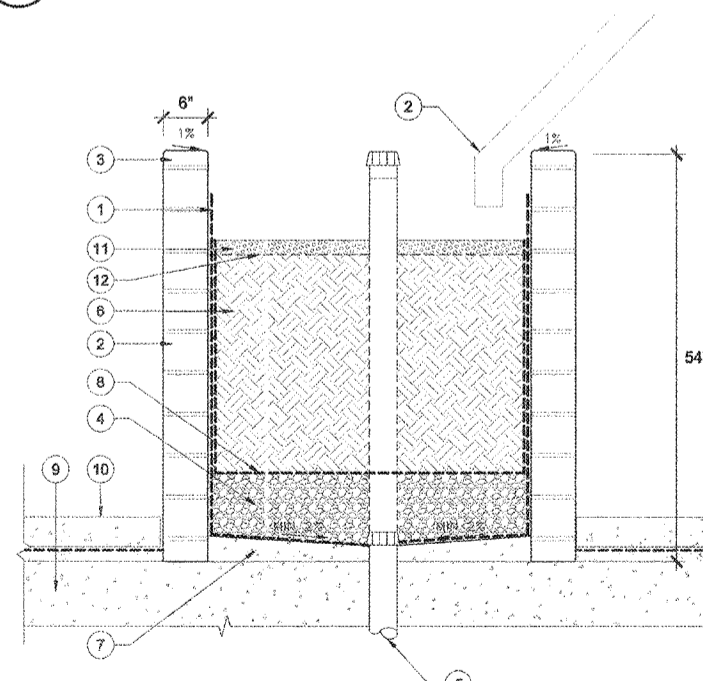

LEGEND

- WATERPROOFING, SEE ARCH DWGS
- 6" CMU WALL, SEE STRUCTURAL DWG
- 2" CMU WALL CAP
- 3/8" CRUSHED ROCK
- DRAINAGE, SEE PLUMBING PLAN
- PLANTING SOIL, SEE SPECIFICATION
- TOPPING SLAB, SLOPE TO DRAIN
- FILTER FABRIC, SEE SPECIFICATIONS
- STRUCTURAL SLAB, SEE STRUCTURAL PLAN
- TOPPING SLAB PAVERS
- 3" LAYER OF MULCH, SEE PLAN/SPECS
- WEED CONTROL FABRIC, SEE SPECS

**4 STORMWATER PLANTER**

SCALE: NTS

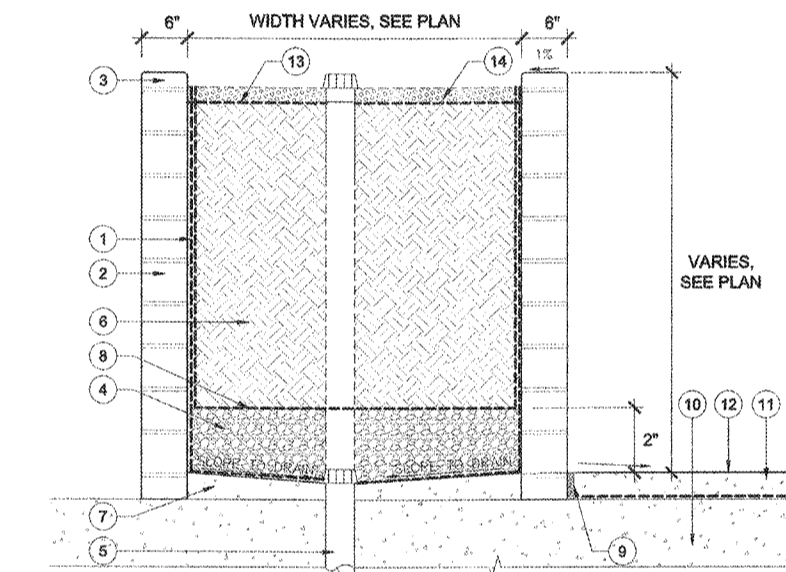

- WATERPROOFING, SEE ARCH DWGS
- 6" CMU WALL, SEE STRUCTURAL DWG
- 2" CMU WALL CAP
- 3/8" CRUSHED ROCK
- DRAINAGE, SEE PLUMBING PLAN
- PLANTING SOIL, SEE SPECIFICATION
- TOPPING SLAB, SLOPE TO DRAIN
- FILTER FABRIC, SEE SPECIFICATIONS
- EXPANSION JOINT
- STRUCTURAL SLAB, SEE STRUCTURE PLAN
- TOPPING SLAB PAVERS
- FS/DRAINAGE, SEE ARCH PLAN
- 3" LAYER OF MULCH, SEE PLAN/SPECS
- WEED CONTROL FABRIC, SEE SPECS

**2 CMU PLANTER ON STRUCTURE**

SCALE: NTS

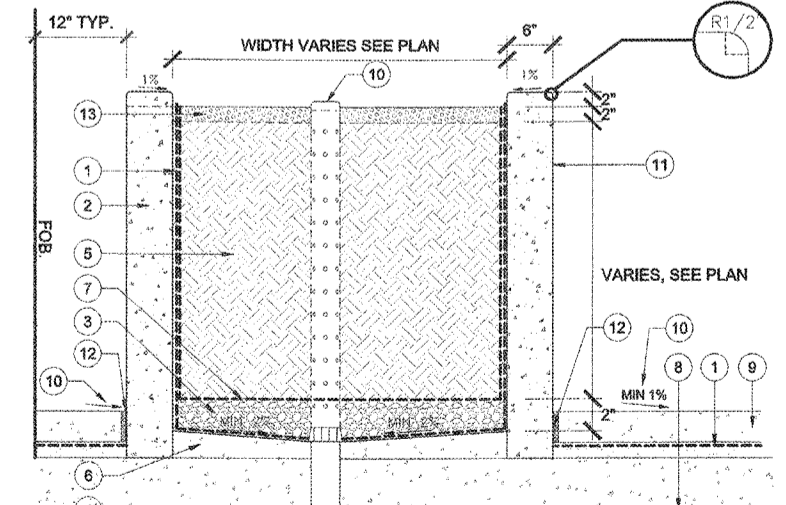

LEGEND

- WATERPROOFING, SEE ARCH PLAN
- STRUCTURAL SLAB & REINFORCEMENT, SEE STRUCTURAL DWG
- 3/8" CRUSHED ROCK
- DRAINAGE, SEE PLUMBING PLAN
- PLANTING SOIL, SEE SPECIFICATION
- TOPPING SLAB, SLOPE TO DRAIN
- FILTER FABRIC, SEE SPECIFICATIONS
- STRUCTURAL SLAB, SEE STRUCTURE PLAN
- TOPPING SLAB PAVERS ADJACENT FS/DRAINAGE, SEE CIVIL PLAN
- CAST IN PLACE CONCRETE PLANTER WALL, SEE SPECIFICATIONS
- EXPANSION JOINT
- 3" MULCH, SEE PLAN/SPECS

**1 CIP PLANTER ON STRUCTURE**

SCALE: NTS

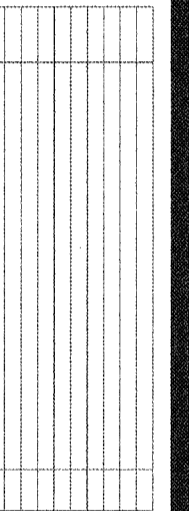

**HOLLYWOOD PARK**  
**RESIDENTIAL - MU-2C**  
INGLEWOOD, CALIFORNIA  
HOLLYWOOD PARK RETAIL AND COMMERCIAL INVESTORS, LLC

**LANDSCAPE CONSTRUCTION**  
**DETAILS**  
**NOT FOR CONSTRUCTION**

THIS SET OF CONSTRUCTION DOCUMENTS HAS BEEN PREPARED FOR THE CONSTRUCTION OF AN APARTMENT PROJECT.

**L1.21**

2017.083  
JOB NUMBER  
SEAL  
PLOT PLAN RESUBMITTAL  
DATE  
06-21-2018  
SCALE DATE