

1. 1/2" OR 3/4" GLASS 24 SQ. FT. MAX. PANEL SIZE FOR EXTERIOR APPLICATIONS
2. TOP OF GLASS FLAT POLISHED EDGE
3. 1.97" DIAMETER BOLT
4. MIN. 14" HEIGHT PLANTER WALL

POOL ENCLOSURE AND BID ALTERNATE:  
GLASS POOL ENCLOSURE BY AQUAVIEW FENCING (877)229-7034

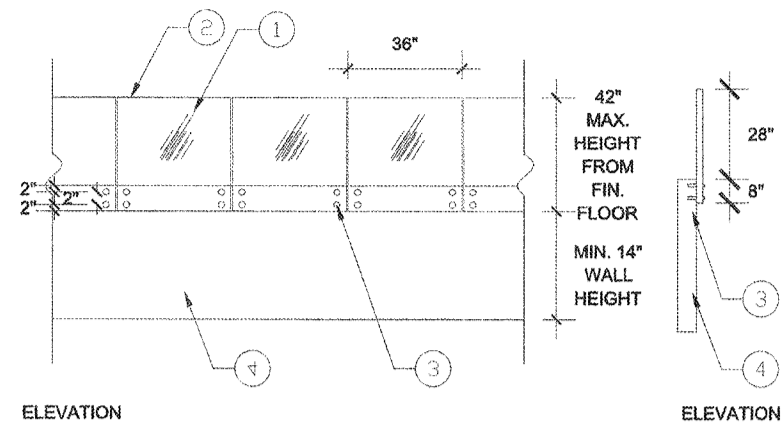

ELEVATION

ELEVATION

NOTES:

1. CONTRACTOR SHALL PROVIDE SHOP DRAWINGS AND MANUFACTURER'S SPECIFICATIONS ON ALL HARDWARE FOR REVIEW AND APPROVAL.
2. ALL DIMENSIONS TO BE VERIFIED IN THE FIELD. CONTRACTOR SHALL VERIFY OPEN DIMENSION AND PLUMBNESS AND TRUENESS OF DOOR OPENING PRIOR TO FINAL SHOP DRAWING.
3. ALL GLASS PANELS TO BE FLUSH AND LEVEL.

**9** GLASS POOL FENCE DETAIL  
SCALE: NTS

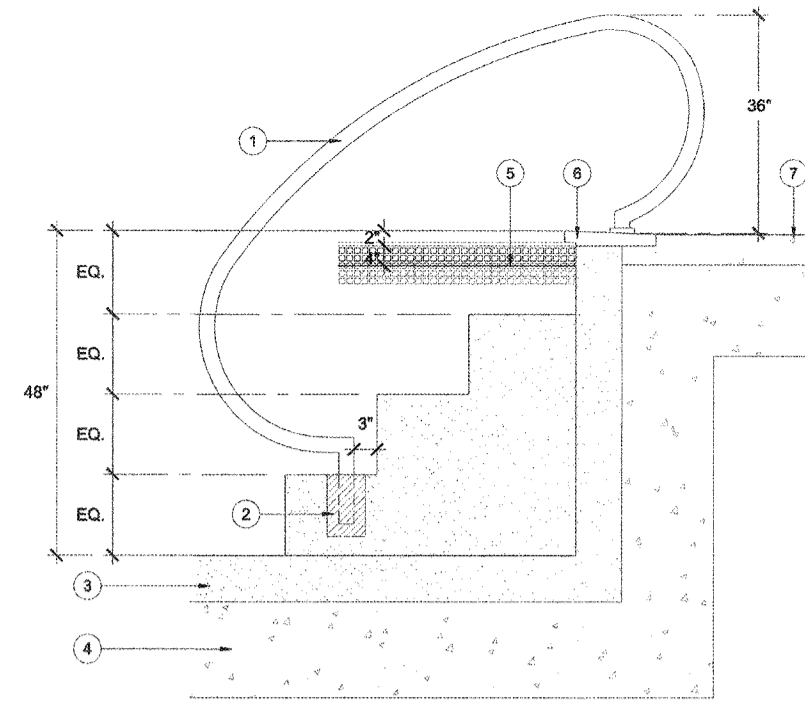

1. 2" DIA. STAINLESS STEEL TUBE HANDRAIL
2. CONCRETE FOOTING
3. GUNITE, PER POOL CONSULTANT
4. STRUCTURAL SLAB, PER STRUCTURAL DWGS
5. WATERLINE
6. CONCRETE COPING, PER POOL CONSULTANT
7. TOPPING SLAB

**6** POOL/SPA HANDRAIL DETAIL  
SCALE: NTS

1. ADJACENT FIRE ACCESS SWINGING GATE
2. PEDESTRIAN ACCESS GATE

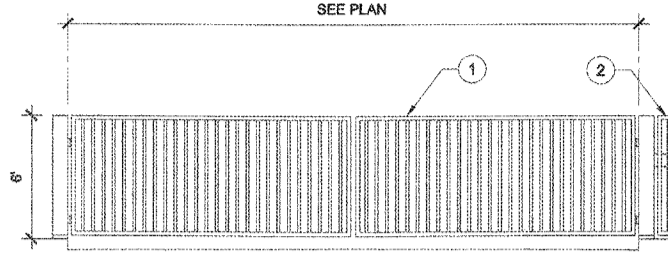

ELEVATION  
NOT TO SCALE

NOTE: FIRE ACCESS SWINGING GATE PER FIRE DEPARTMENT APPROVAL

**3** DOUBLE-SWING WROUGHT IRON FIRE ACCESS GATE  
SCALE: NTS

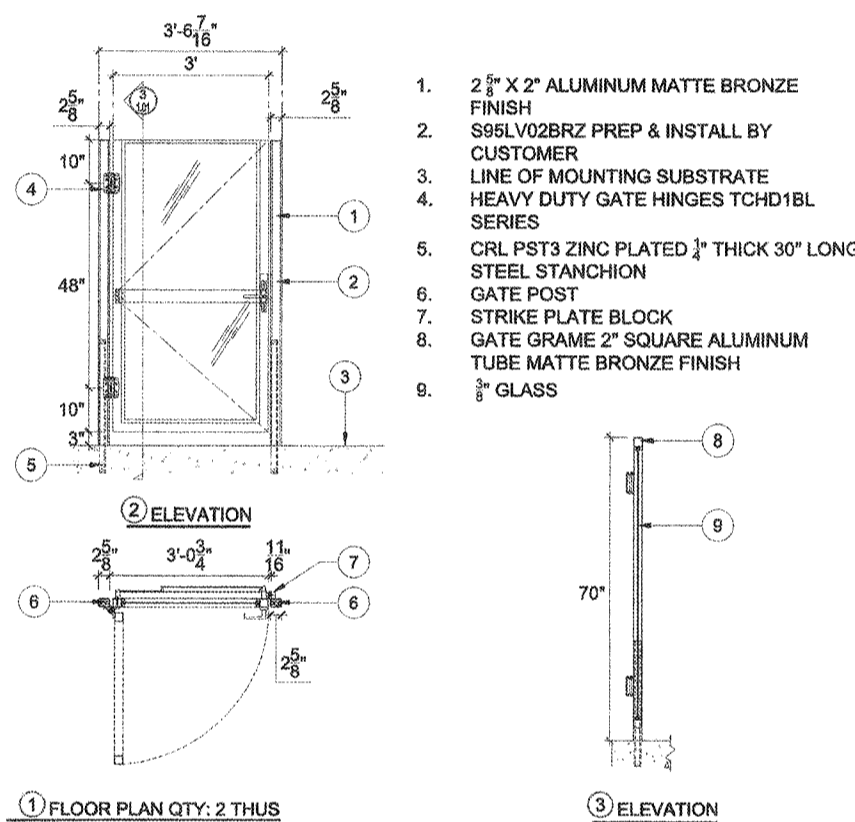

1 FLOOR PLAN QTY: 2 THUS

3 ELEVATION

1. 2 1/2" X 2" ALUMINUM MATTE BRONZE FINISH
2. S95LV02BRZ PREP & INSTALL BY CUSTOMER
3. LINE OF MOUNTING SUBSTRATE
4. HEAVY DUTY GATE HINGES TCHD1BL SERIES
5. CRL PST3 ZINC PLATED 3/8" THICK 30" LONG STEEL STANCHION
6. GATE POST
7. STRIKE PLATE BLOCK
8. GATE FRAME 2" SQUARE ALUMINUM TUBE MATTE BRONZE FINISH
9. 3/8" GLASS

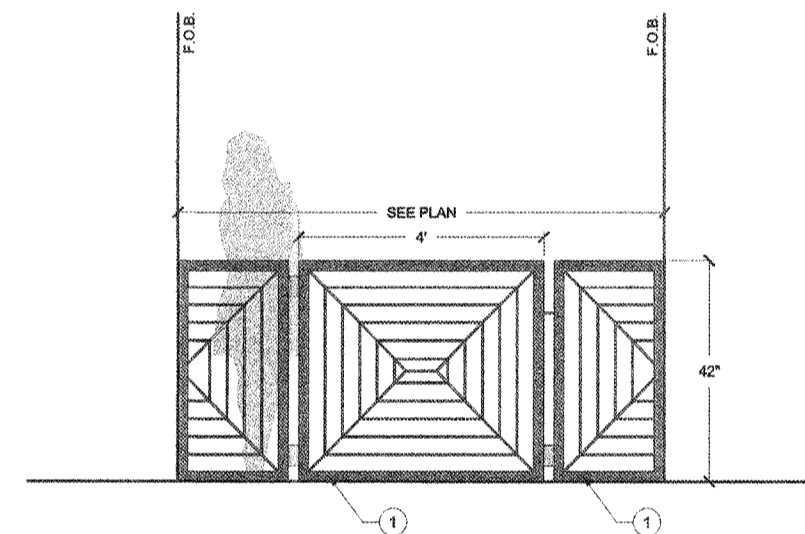

ELEVATION  
NOT TO SCALE

1. 2"X3" FRAME BLACK WROUGHT IRON GATE

**5** CUSTOMED WROUGHT IRON GATE OPTION 1  
SCALE: NTS

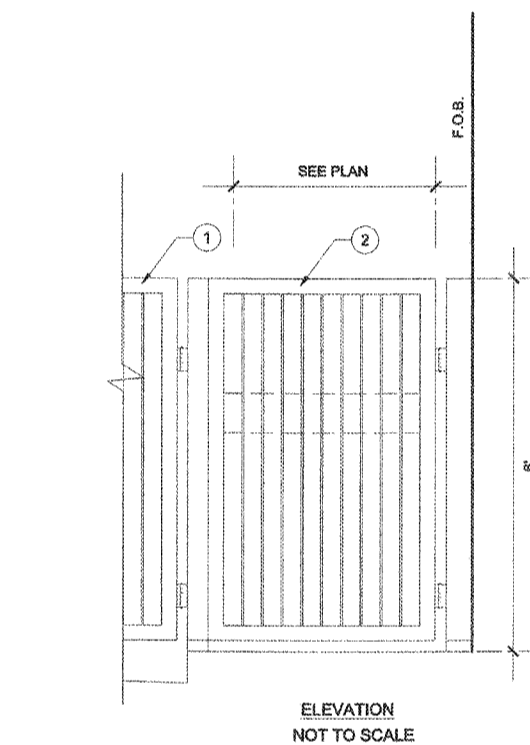

ELEVATION  
NOT TO SCALE

1. ADJACENT FIRE ACCESS SWINGING GATE
2. PEDESTRIAN ACCESS GATE

**2** PEDESTRIAN GATE  
SCALE: NTS

**11** 13' POLE FOR STRING LIGHTS  
SCALE: NTS

**8** GLASS POOL GATE DETAIL  
SCALE: NTS

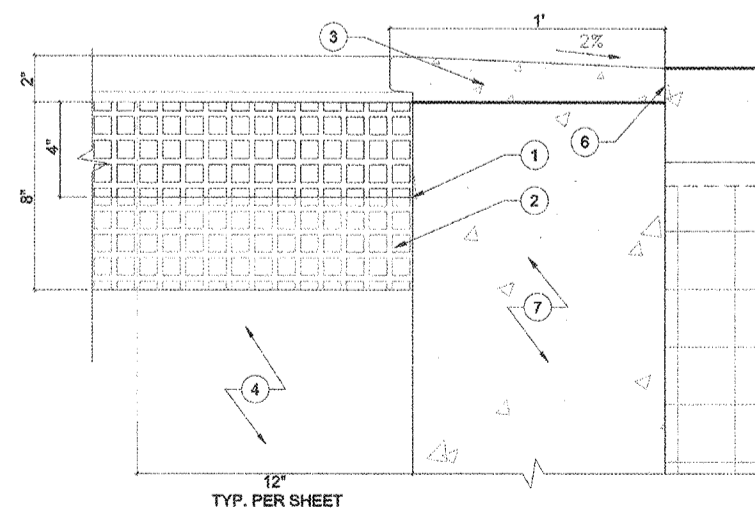

1. WATERLINE, SEE 2/LC4.04
2. WATERLINE TILE MANUFACTURER: DAL TILE COLLECTION: GLASS HORIZONS COLOR: SKY BLUE 01 SIZE: 3/4" X 3/4" MOSIC CONTACT: (214)398 1411
3. 1" PRECAST CONCRETE COPING [E-101]
4. POOL, SEE POOL CONSULTANT PLAN
5. POURED IN PLACE TOPPING SLAB, SEE ARCH PLAN
6. EXPANSION JOINT, SEE ARCH PLAN
7. POOL SHELL, SEE POOL CONSULTANT PLAN

**10** POOL COPING DETAIL  
SCALE: NTS

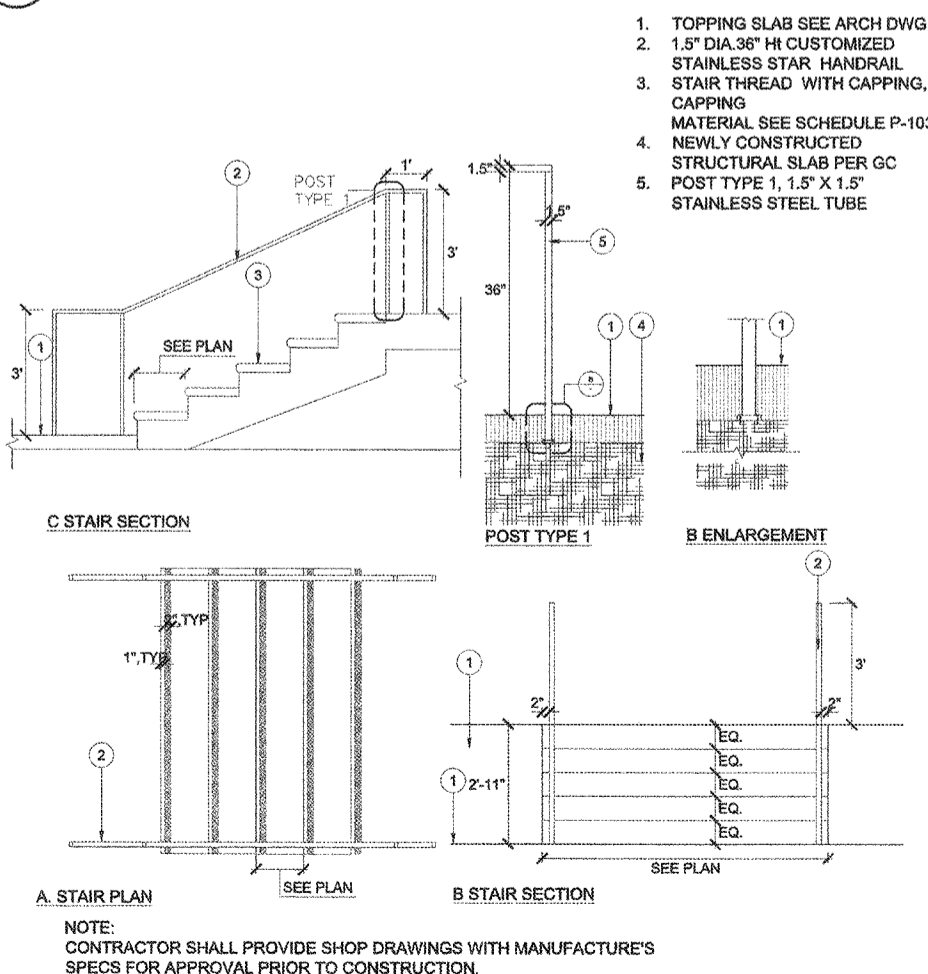

**7** STAIRS WITH HANDRAIL DETAIL  
SCALE: NTS

1. TOPPING SLAB SEE ARCH DWG
2. 1.5" DIA. 36" H CUSTOMIZED STAINLESS STAR HANDRAIL
3. STAIR THREAD WITH CAPPING, CAPPING MATERIAL SEE SCHEDULE P-103
4. NEWLY CONSTRUCTED STRUCTURAL SLAB PER GC
5. POST TYPE 1, 1.5" X 1.5" STAINLESS STEEL TUBE

NOTE:  
CONTRACTOR SHALL PROVIDE SHOP DRAWINGS WITH MANUFACTURE'S SPECS FOR APPROVAL PRIOR TO CONSTRUCTION.

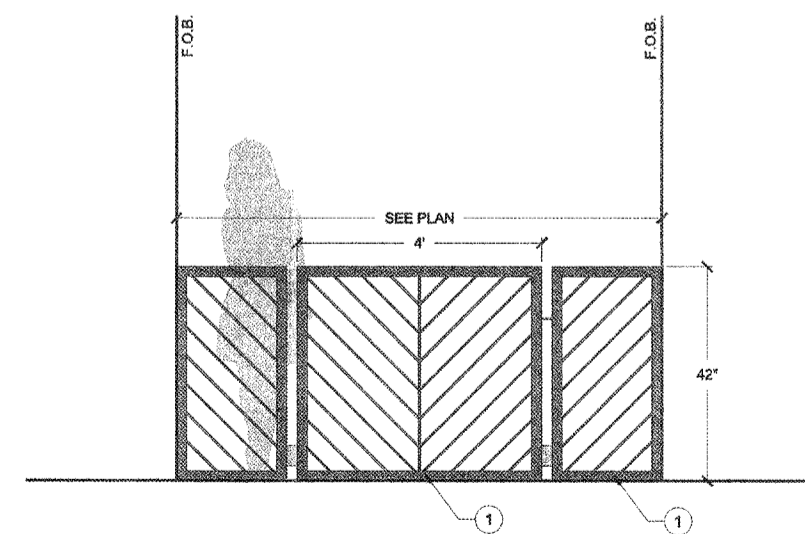

ELEVATION  
NOT TO SCALE

1. 2"X3" FRAME BLACK WROUGHT IRON GATE

**4** CUSTOMED WROUGHT IRON GATE OPTION 2  
SCALE: NTS

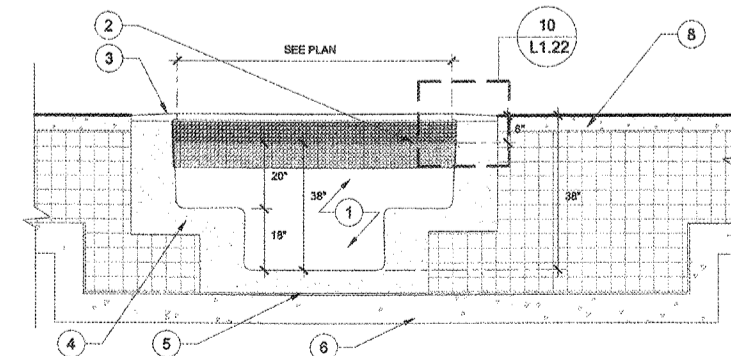

1. JACUZZI UNDER SEPERATED PACKAGE
2. WATERLINE
3. PRECAST CONCRETE COPING TO MATCH TOPPING SLAB, SEE POOL CONSULTANT PLAN
4. POOL SHELL, SEE POOL CONSULTANT PLAN
5. WATER PROOFING, SEE ARCH PLAN
6. STRUCTURE SLAB, SEE STRUCTURE PLAN
7. ADJACENT SEATING WALL
8. TOPPING SLAB, SEE ARCH PLAN

**1** SPA DETAIL  
SCALE: NTS